

Fluted Cladding Installation Guide



Feelingwood

CONTENTS

Important Note	3-4
Cladding Parts Overview	5
Cladding Parts Introduction	6
Vertical Installation	7-13
Horizontal Installation	14-15

Important Note

Before installing any composite product, it is recommended that you check your local building codes for any special requirements or restrictions. The diagrams and instructions outlined in this guide are for illustrative purposes only and are not meant or implied to replace a licensed professional. Any construction or use of Hosung products must comply with all local zoning and/or building codes. The consumer assumes all risks and responsibilities associated with the construction and use of this product.

Safety

Please take safety precautions before installing the cladding, check that the equipment is working properly and is free of malfunctions, and wear protective safety props such as gloves, goggles, and impact resistant shoes.

Environment

Proper installation of Feelingwood products requires a clean, smooth, flat and sturdy surface. Check with local building codes before installing any type of cladding. If installation is not immediate, Hosung's products need to be placed on a flat surface at all times. Never place on an uneven surface.

Planning

Plan the layout for your cladding before you begin to ensure you get the best look for your cladding project. Building codes and zoning ordinances usually apply to permanent structures, i.e., any structure that is attached to a house. As a result, almost every type of cladding requires permits and inspections from your local building department. We recommend planning the overall layout approach and scope of the layout prior to installation to try to avoid mistakes in this area.

Heat and Fire

Excessive heat on the surface of Feelingwood products from external sources such as but not limited to fire or reflection of sunlight from energy efficient window products. Low-emissivity (Low-E) glass can potentially harm Feelingwood products. Low-E glass is designed to prevent passive heat gain within a structure and can cause unusual heat build-up on exterior surfaces. This extreme elevation of surface temperatures, which exceeds that of normal exposure, can possibly cause Hosung products to melt, sag, warp, discolor, increase expansion/contraction, and accelerate weathering.

Fasteners

When fastening Feelingwood's products, all screws that are face fastened should always be driven in at a 90 degree angle to the cladding surface. Toe nailing/screwing should never be done to the products. An extra joist should be added if a 90 degree angle cannot be driven into the board. All fasteners should be on their own independent joists, when two boards ends meet each other, there must be a sister joist. The end of each board must sit on its own joist.

Use white chalk, straight boards, or string lines as templates for straight lines. NEVER USE COLORED CHALK, Colored chalk will permanently stain Hosung's products and are highly not recommended.

All nails/screws that are face fixed should always be stainless steel. Depending on the screws that you use when face fixing, there could be potential bulging or mushrooming. It is recommended to take care of these mushrooms/bulges by taking a rubber mallet and patting them down to give your cladding a better look.

If you need to replace the screws yourself, be sure to check first with your local home centers and

hardware stores to see if they have screws that are engineered specifically for composite wood. These screws/nails will always work and give Feelingwood's products the best looking outcome. Using other screws/nails that are not recommended for composite could potentially damage/harm the cladding. If you are unsure which screw/nail to use, contact your manufacturer for more information.

Pre-drill

It is recommended to use the #8 screw for face fixing the boards and the trims onto the joist. When face fixing, it is recommended to pre-drill a slightly bigger hole on the board and the trim to allow for expansion and contraction, as shown in the below diagram.

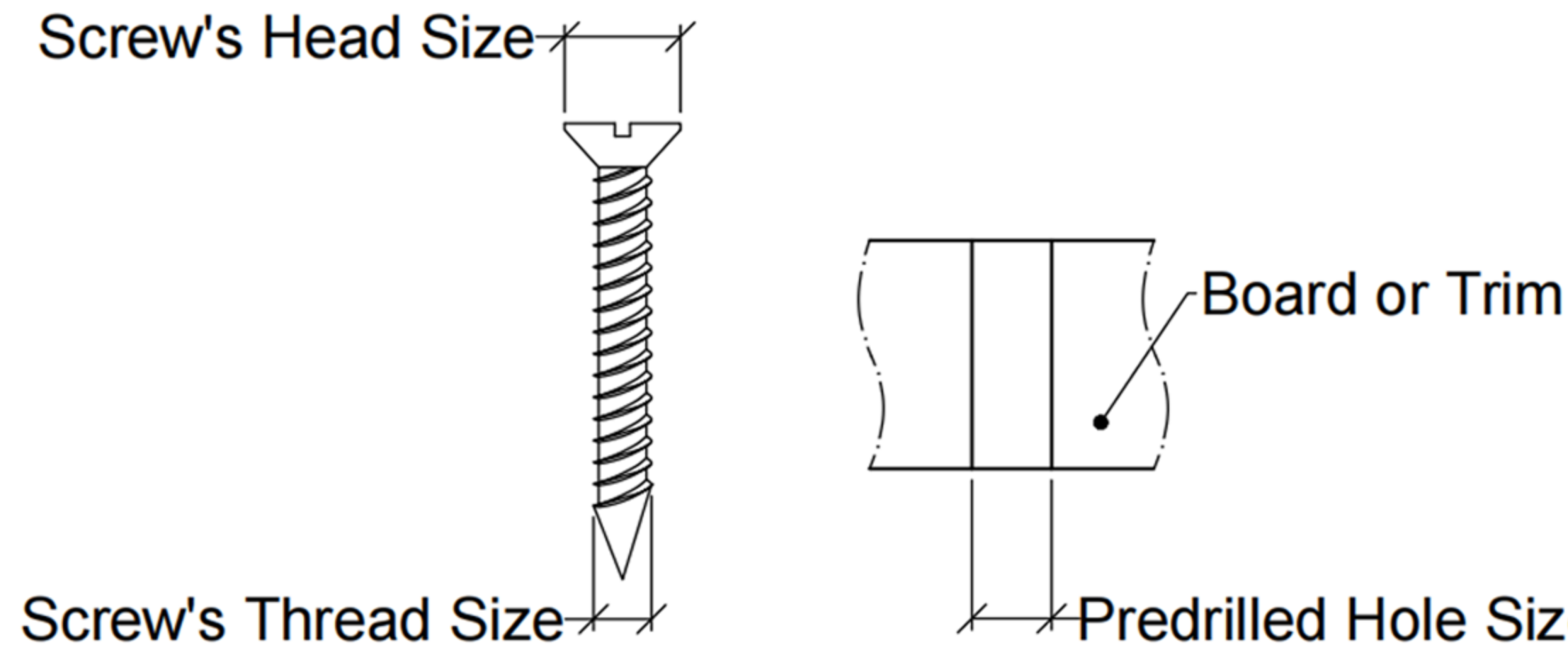

The pre-drilled hole size should be larger than the screw's thread size, from 1.5 mm (1/16") to 2mm (5/64"). Moreover, the pre-drilled hole size should also be smaller than the screw's head size, at least 2mm (5/64"). A washer can be applied if the screw's head size is larger than the pre-drilled hole size, if it's below 2mm (5/64").

Joist Installation

A building professional should be consulted regarding vapor barriers and insulation for your project. Where a vapor barrier is to be used, it should be a breathable type and must be positioned behind the joists. The joist needs to have a minimum thickness of 30mm.

Use a suitable A4 Stainless Steel Countersunk Wood/Masonry screw. All joists need to be flat and leveled against the wall surface use shims if necessary.

Expansion and Contraction Values

Feelingwood cladding boards will experience expansion and contraction with changes in temperature. Expansion and contraction are the most significant where extreme temperature changes occur. Fastening the cladding boards according to the gapping requirements noted in the following table accommodates for this movement.





Expansion and Contraction Table of Values

		Length (Feet)							
		3	8	9	10	12	13	16	18
Installation temperature	32	1/16	2/16	2/16	3/16	3/16	4/16	4/16	5/16
	41	1/16	2/16	2/16	2/16	3/16	3/16	4/16	4/16
	50	1/16	2/16	2/16	2/16	2/16	3/16	3/16	3/16
	59	1/16	1/16	1/16	2/16	2/16	2/16	2/16	3/16
	68	3/64	1/16	1/16	1/16	1/16	2/16	2/16	2/16
	77	3/64	1/16	1/16	1/16	1/16	1/16	1/16	1/16
	86	3/64	3/64	3/64	3/64	3/64	1/16	1/16	1/16

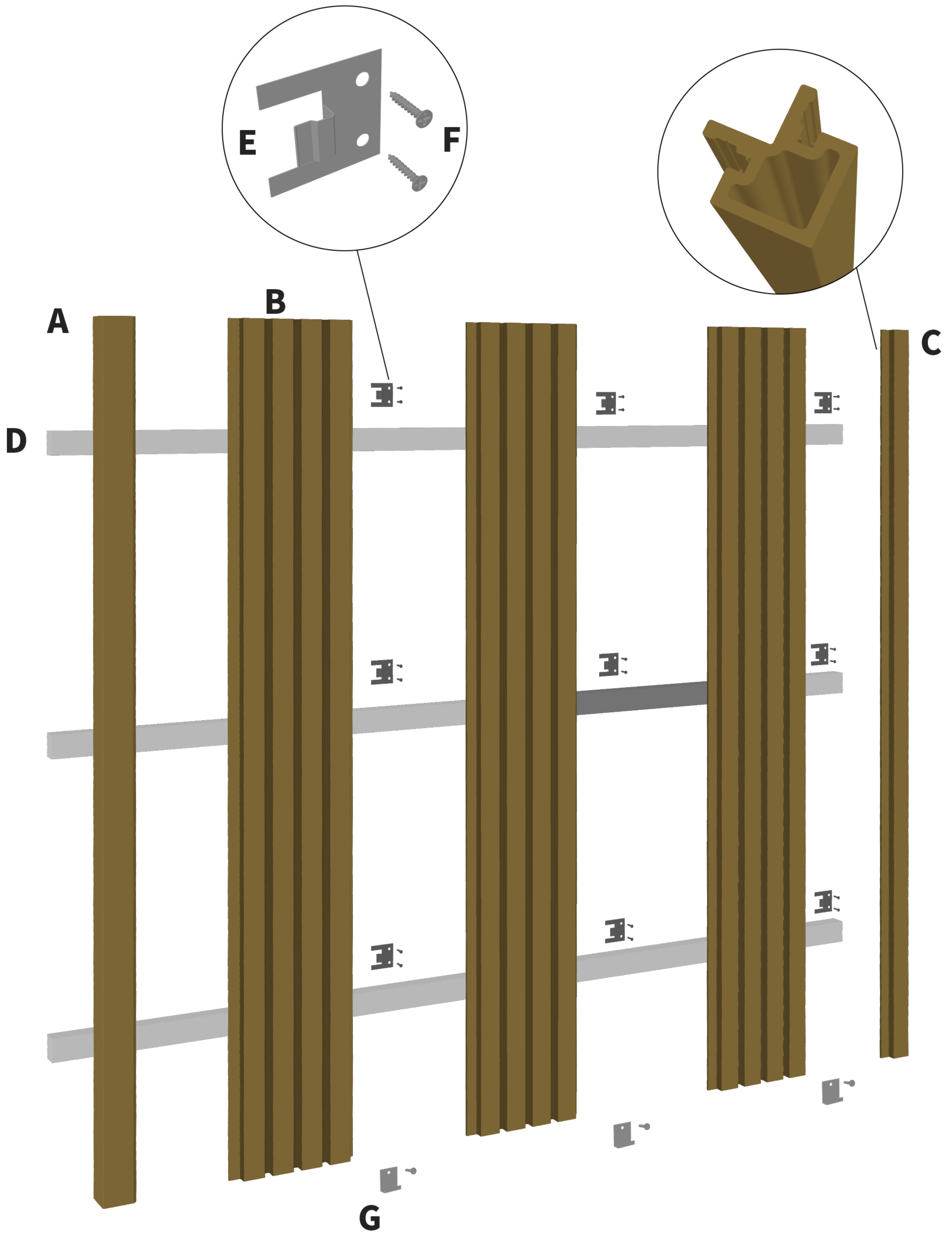
Note: If you are still unsure of what gapping to use, contact us and we will give you the correct gapping requirements based on your environment and area.

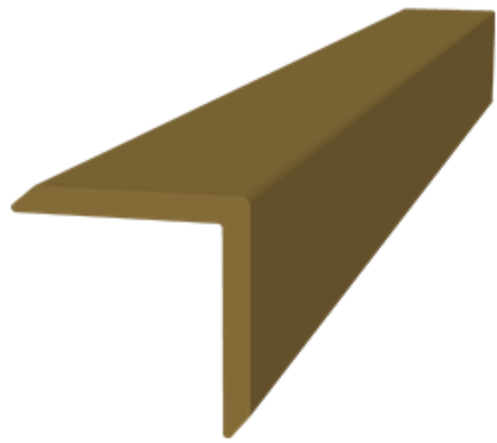
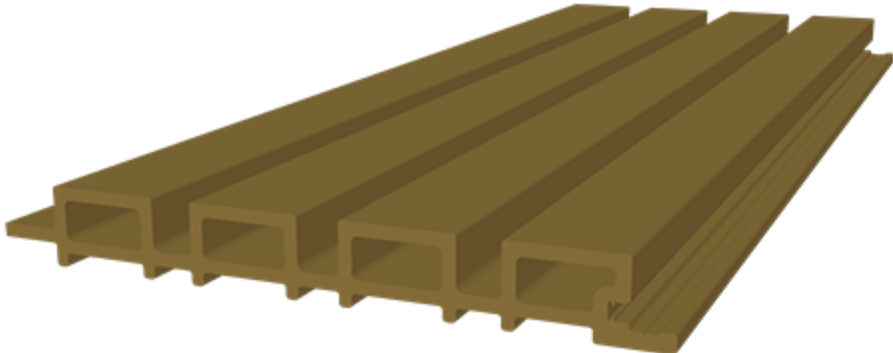
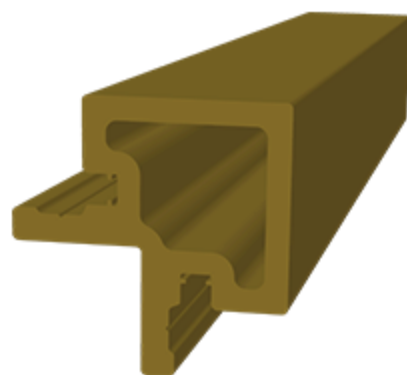
Cladding Parts Overview

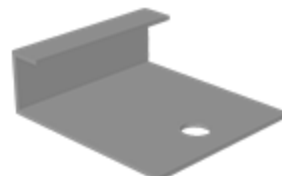

<u>Code</u>		<u>Description</u>
A		L Trim
B		Cladding Panel
C		Corner Trim
D		Joist
E		Connector Clip
F		Screw
G		Starter Clip

Tool List

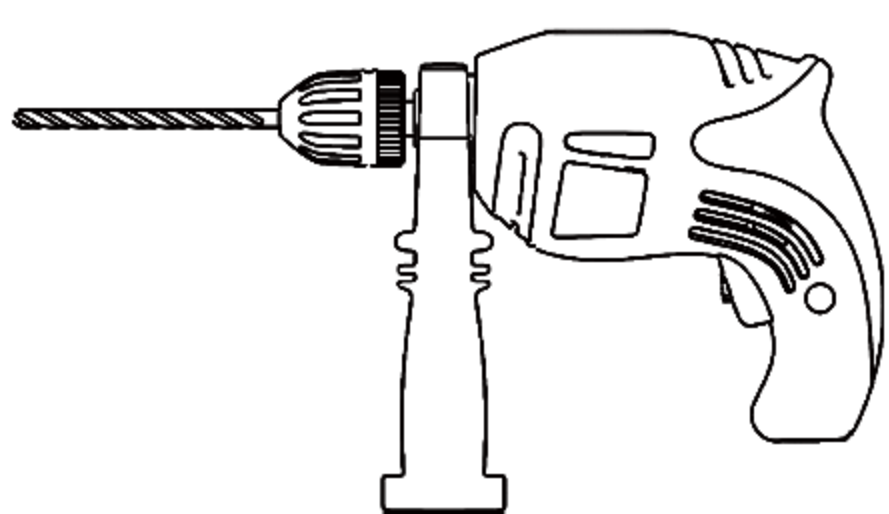

Impact Drill

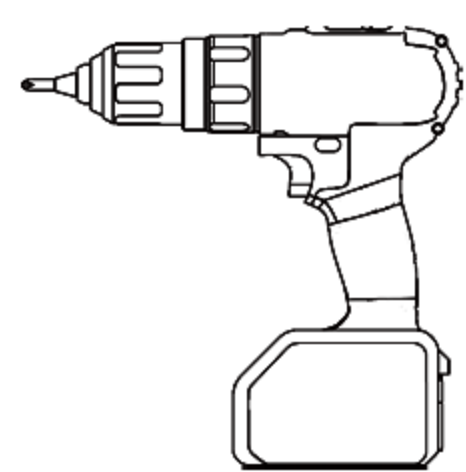

Electric Drill

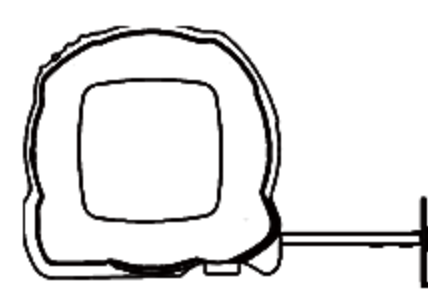

Tape Measure



Hammer

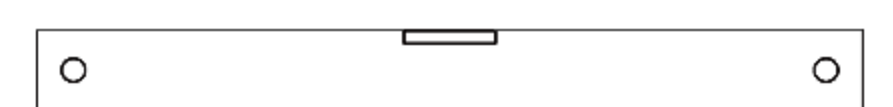

Spirit Level

Vertical Installation

1 Install joists onto the wall with a 500mm span between adjacent joists. The topmost joist should be positioned 10mm from the top of the wall (see Detail 1-1) and the bottommost joist should be positioned 20mm from the ground (see Detail 1-2). Secure the joists to the wall with screws at 500mm spans. Install 2 starter clips onto the bottommost joist. Position the first starter clip 4mm (center distance) from the edge of the joist, and the second one 14mm (center distance) from the same edge.

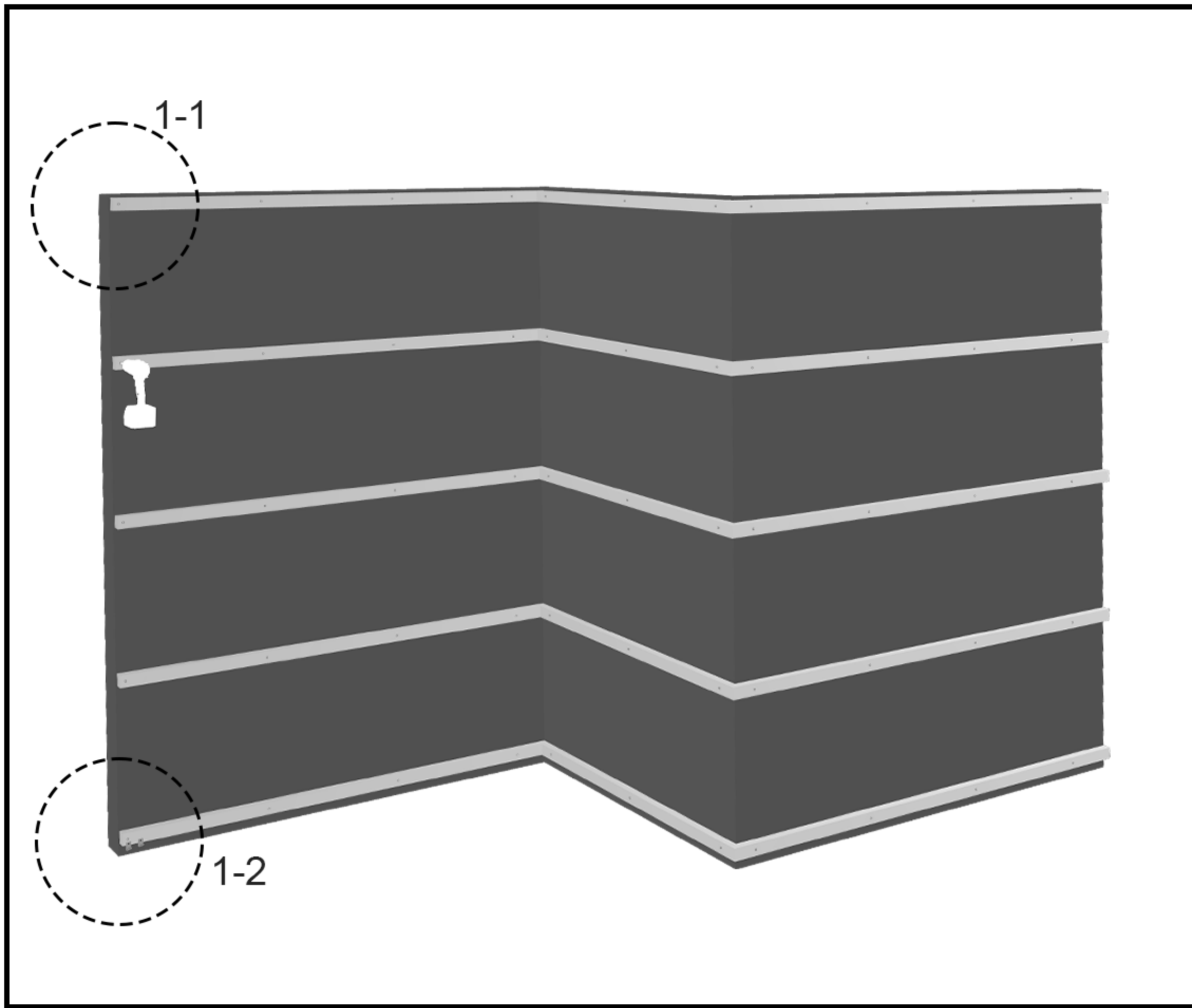

Diagram 1

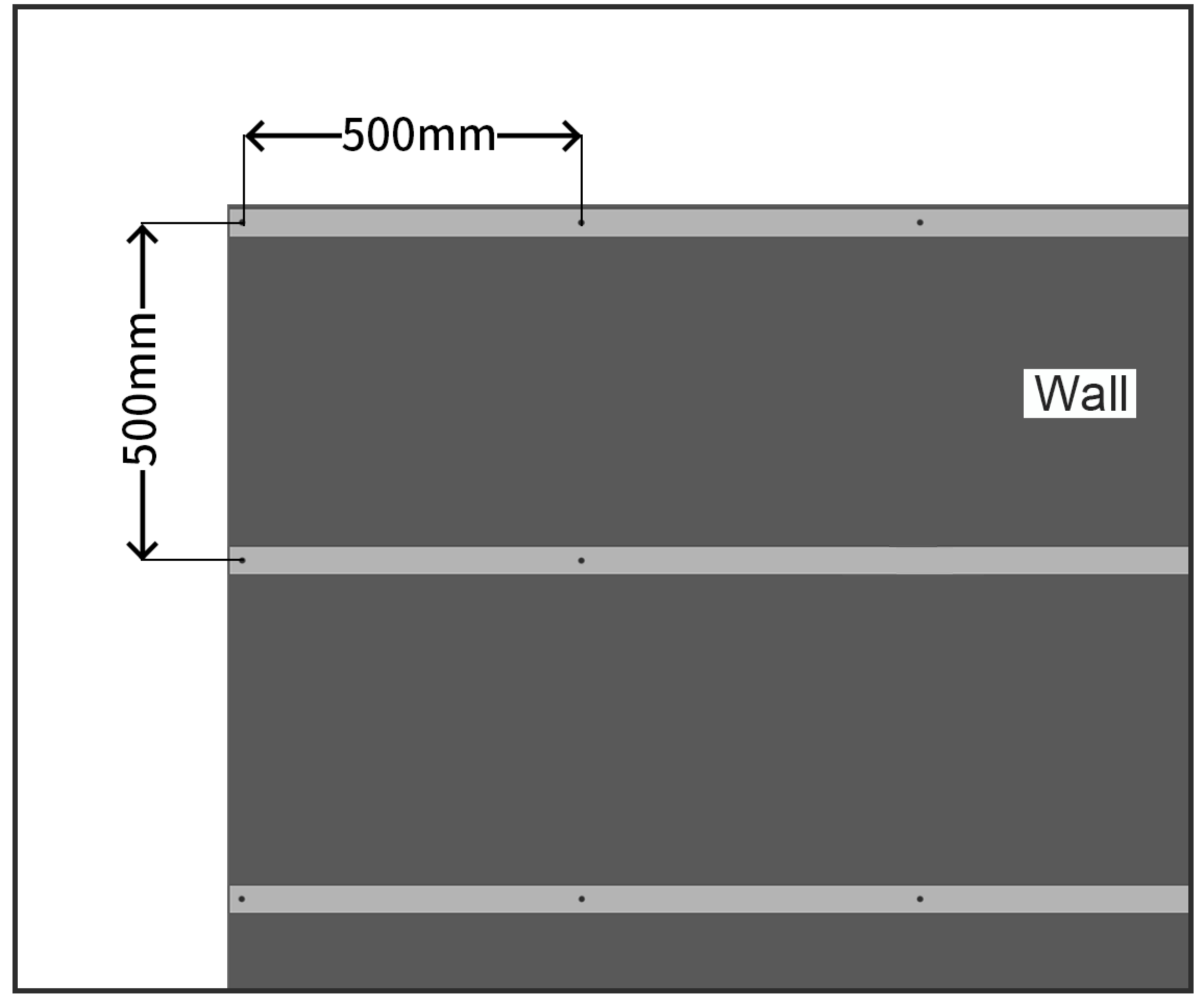
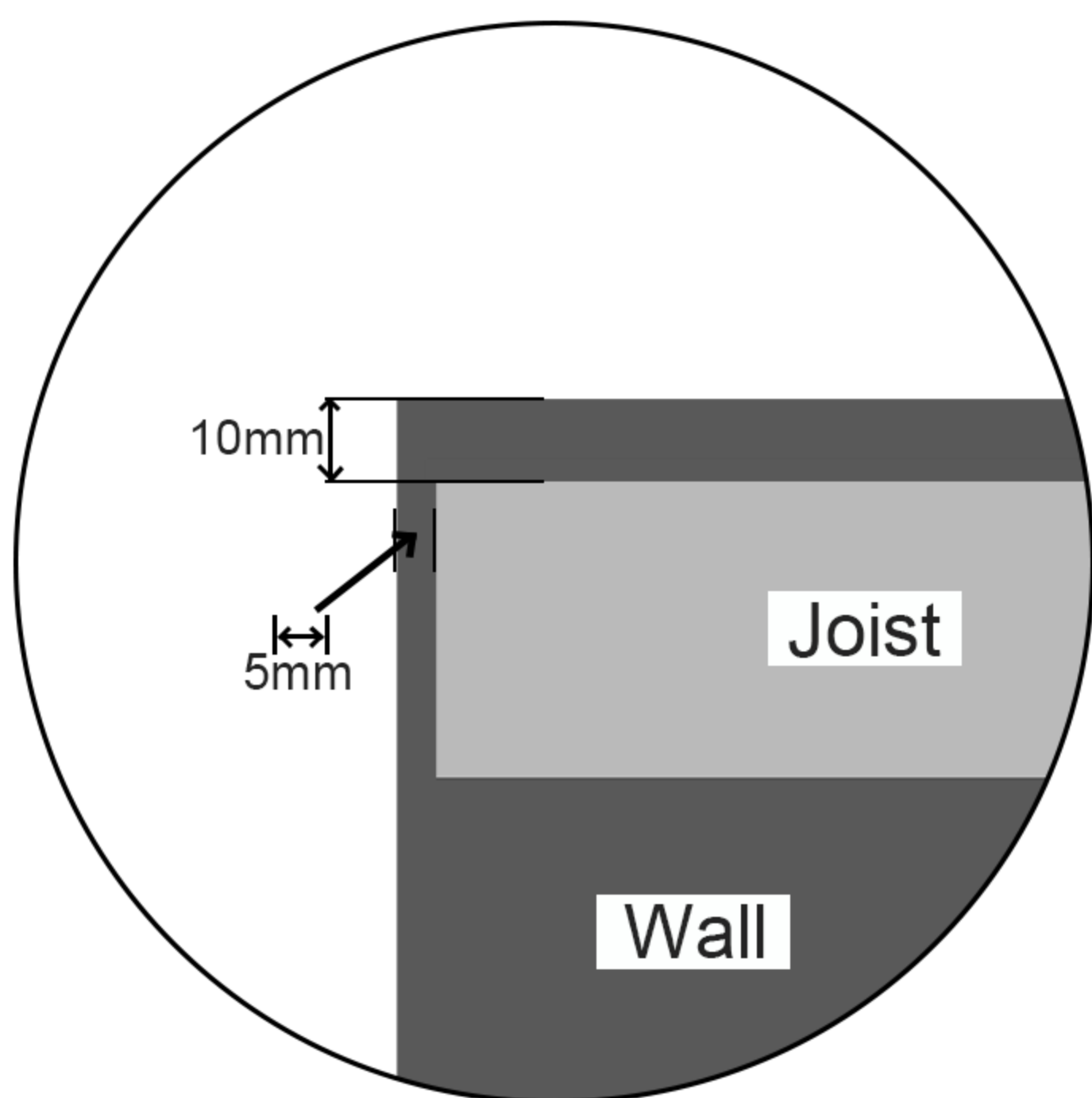
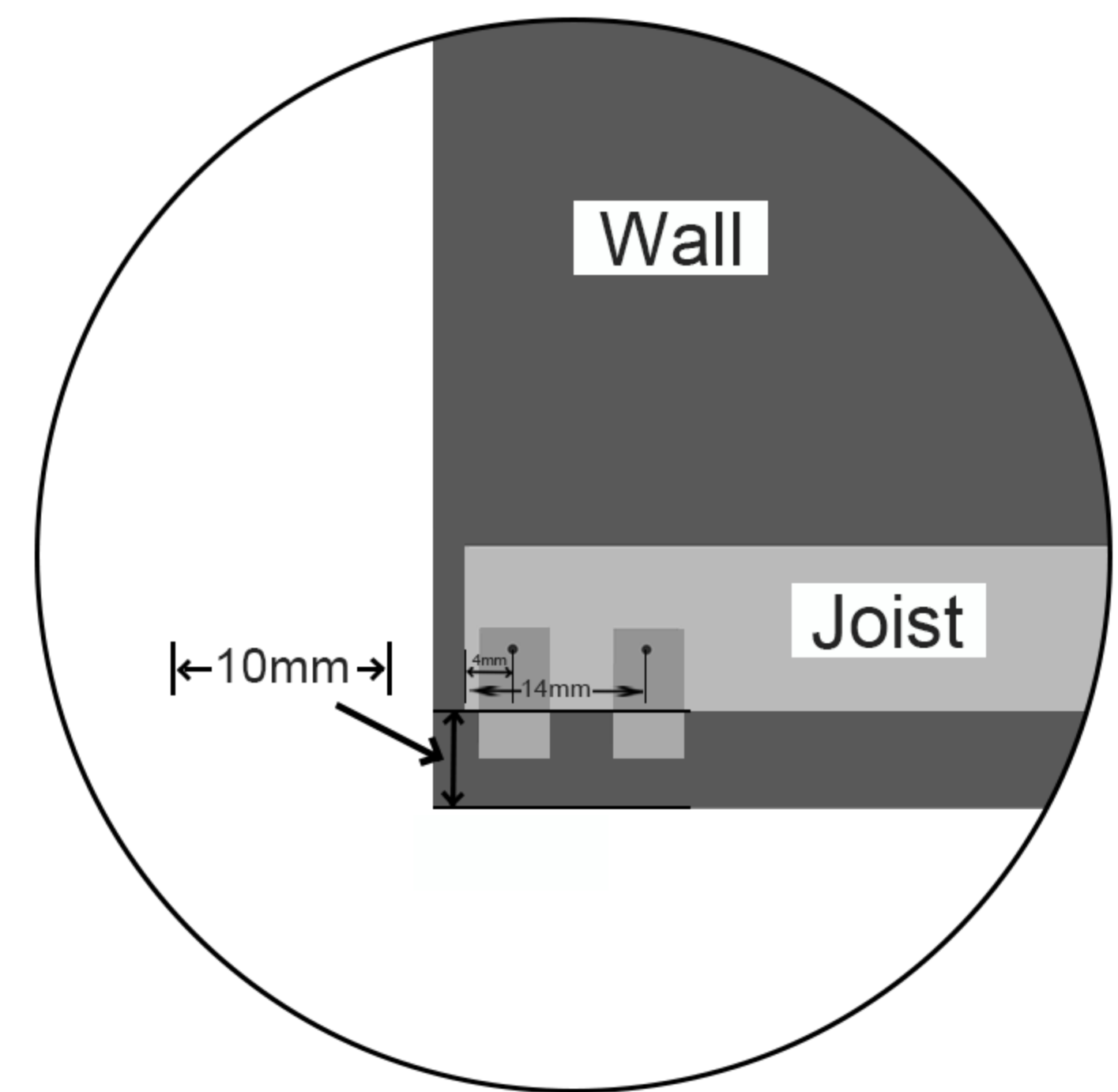

Diagram 2



Detail 1-1



Detail 1-2

- 2** Take a cladding panel and put it in line with the edge of the joists and insert it into the starter clips (as shown in Diagram 3). Then insert connector clips in line with the right side of wall panel, and screw them onto the joists (see Detail 3-1).

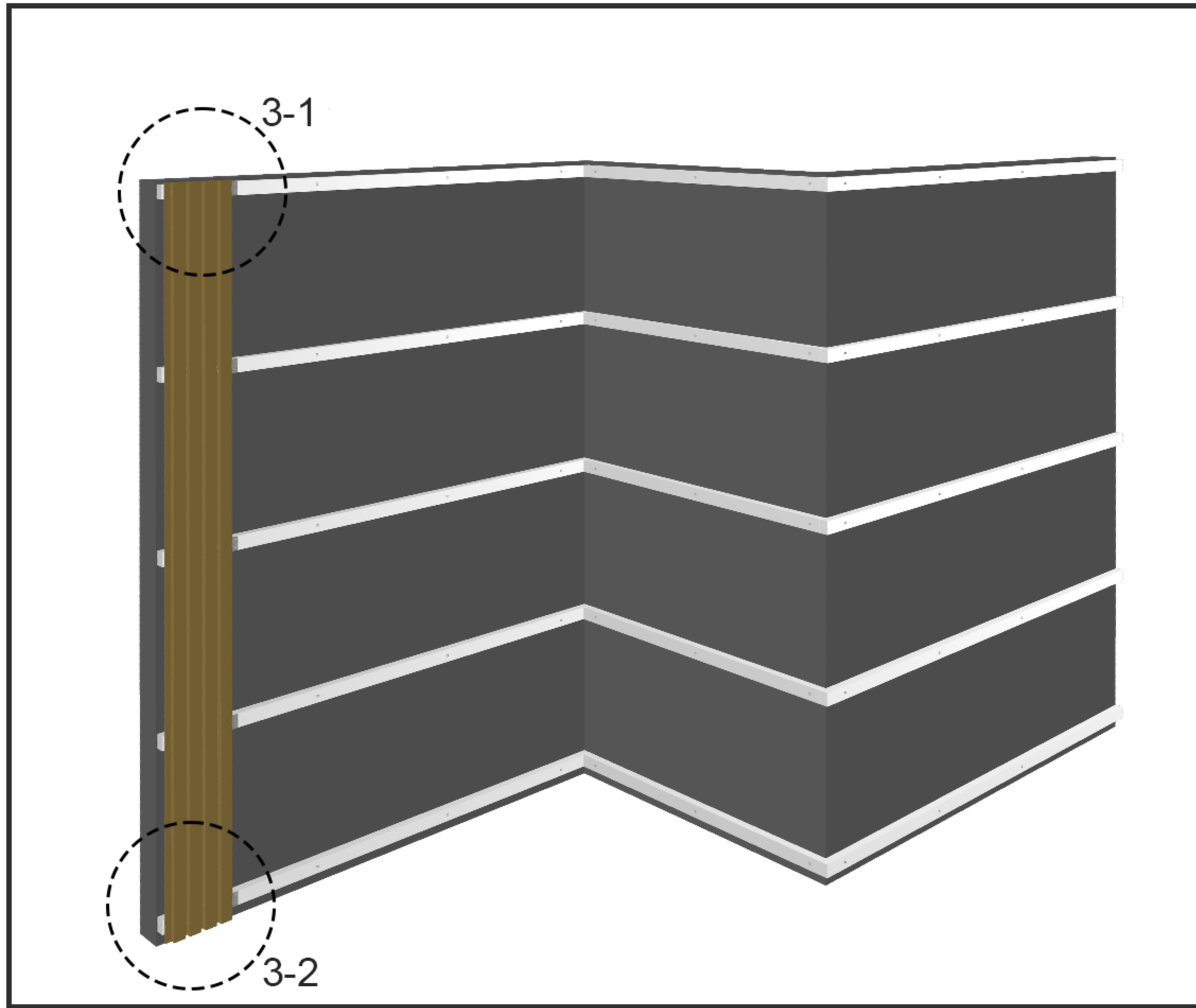
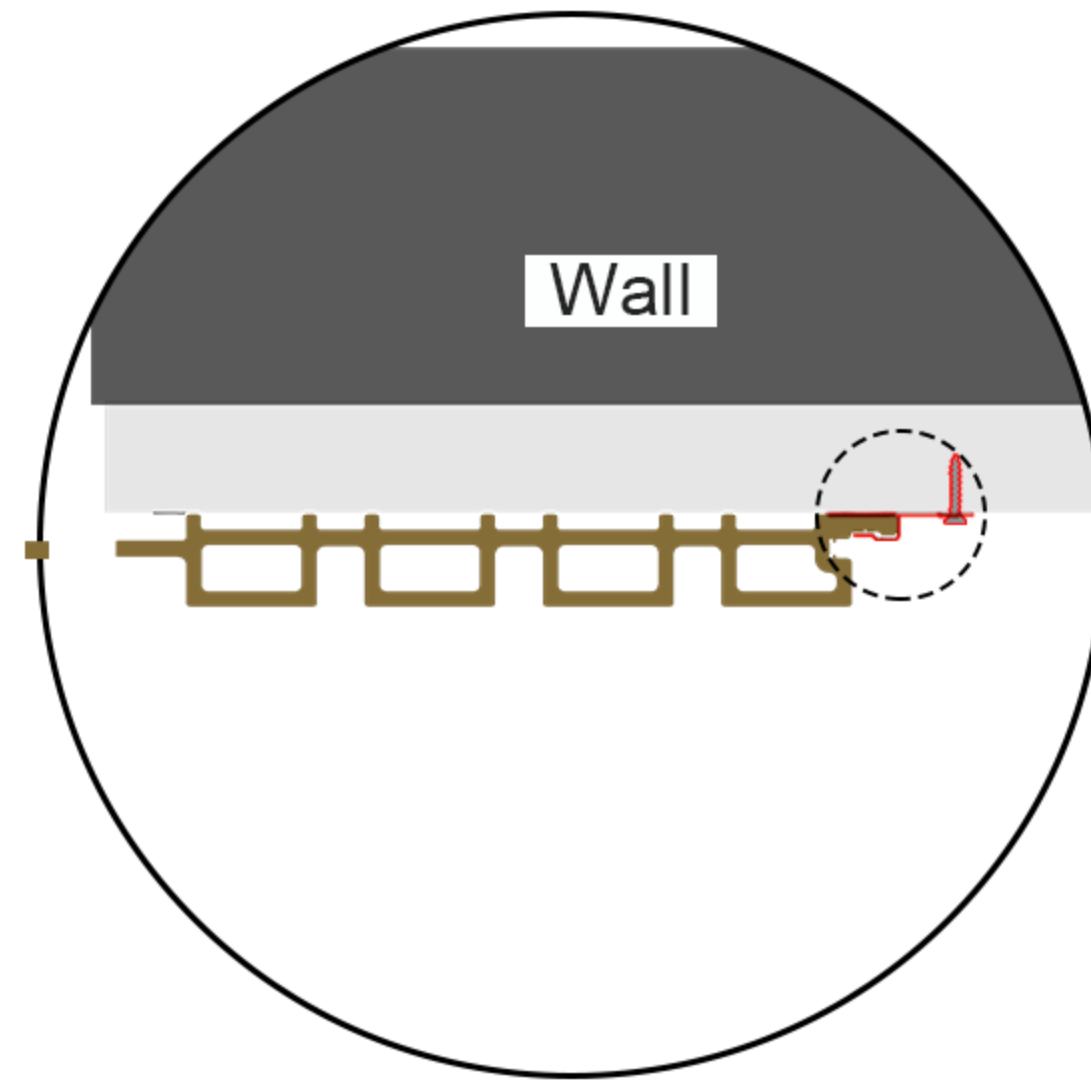
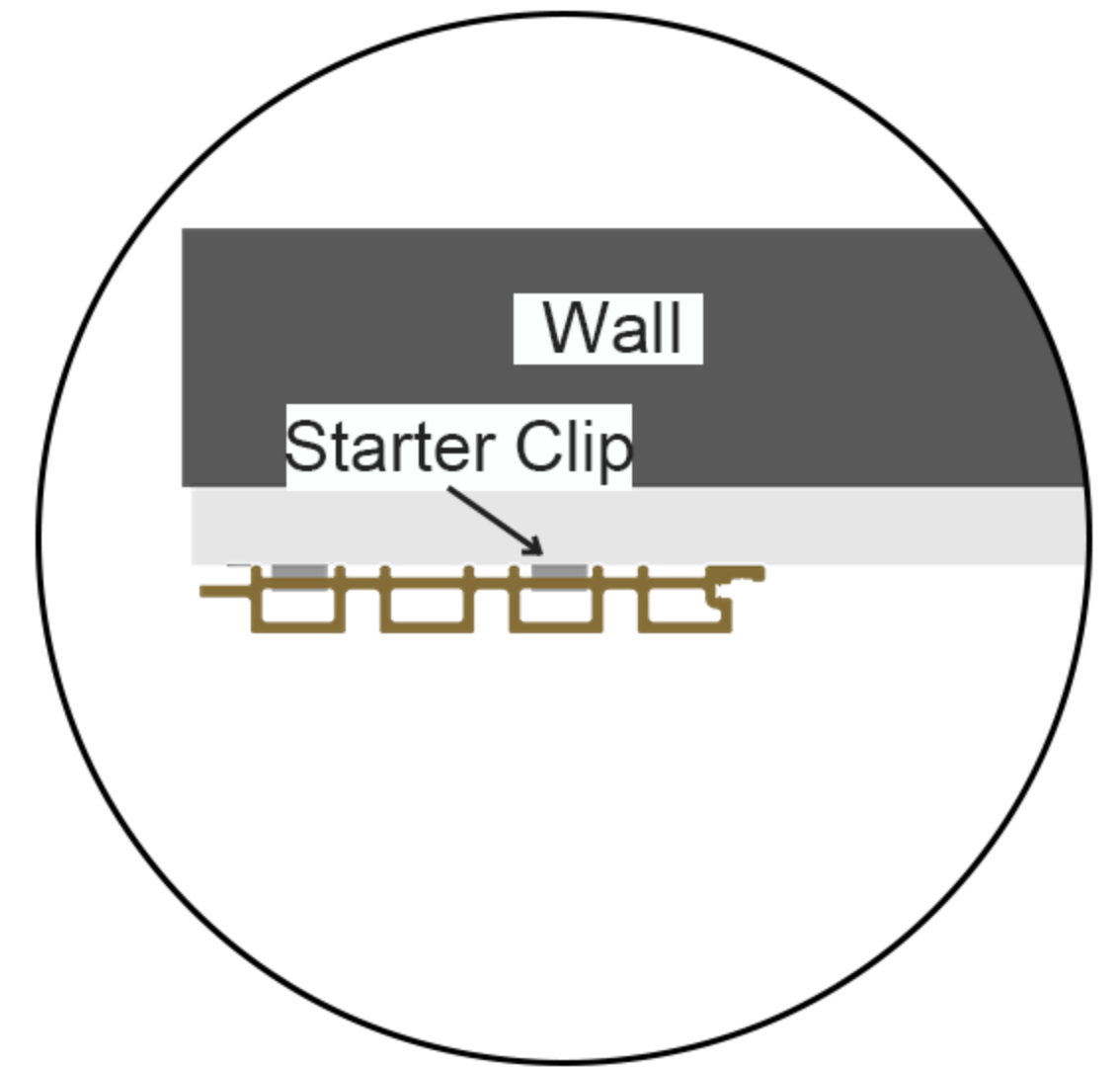

Diagram 3



Detail 3-1



Detail 3-2

- 3** Repeat this step by fixing the second wall panel into clips. Ensure proper alignment by following Detail 4-1.

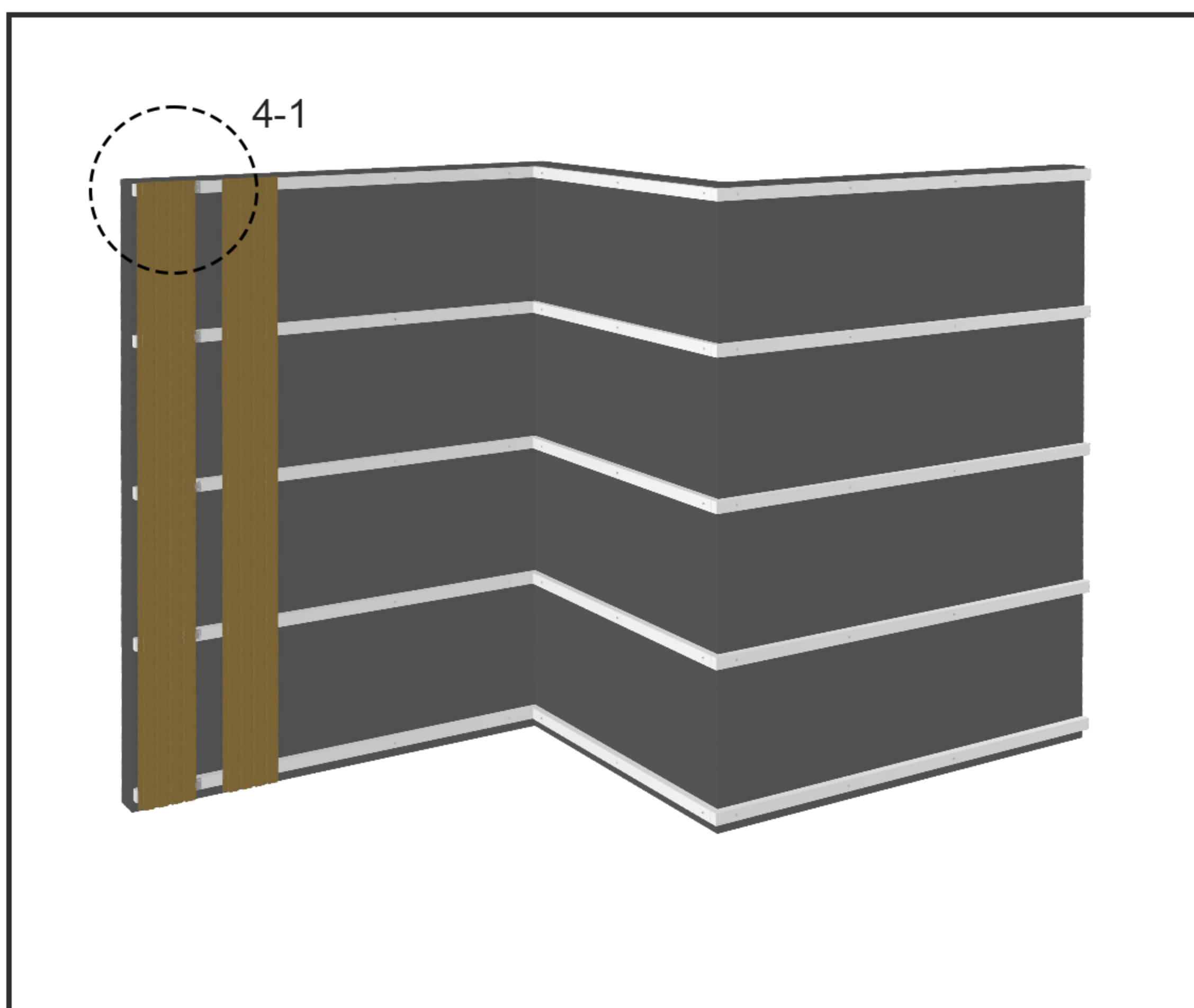
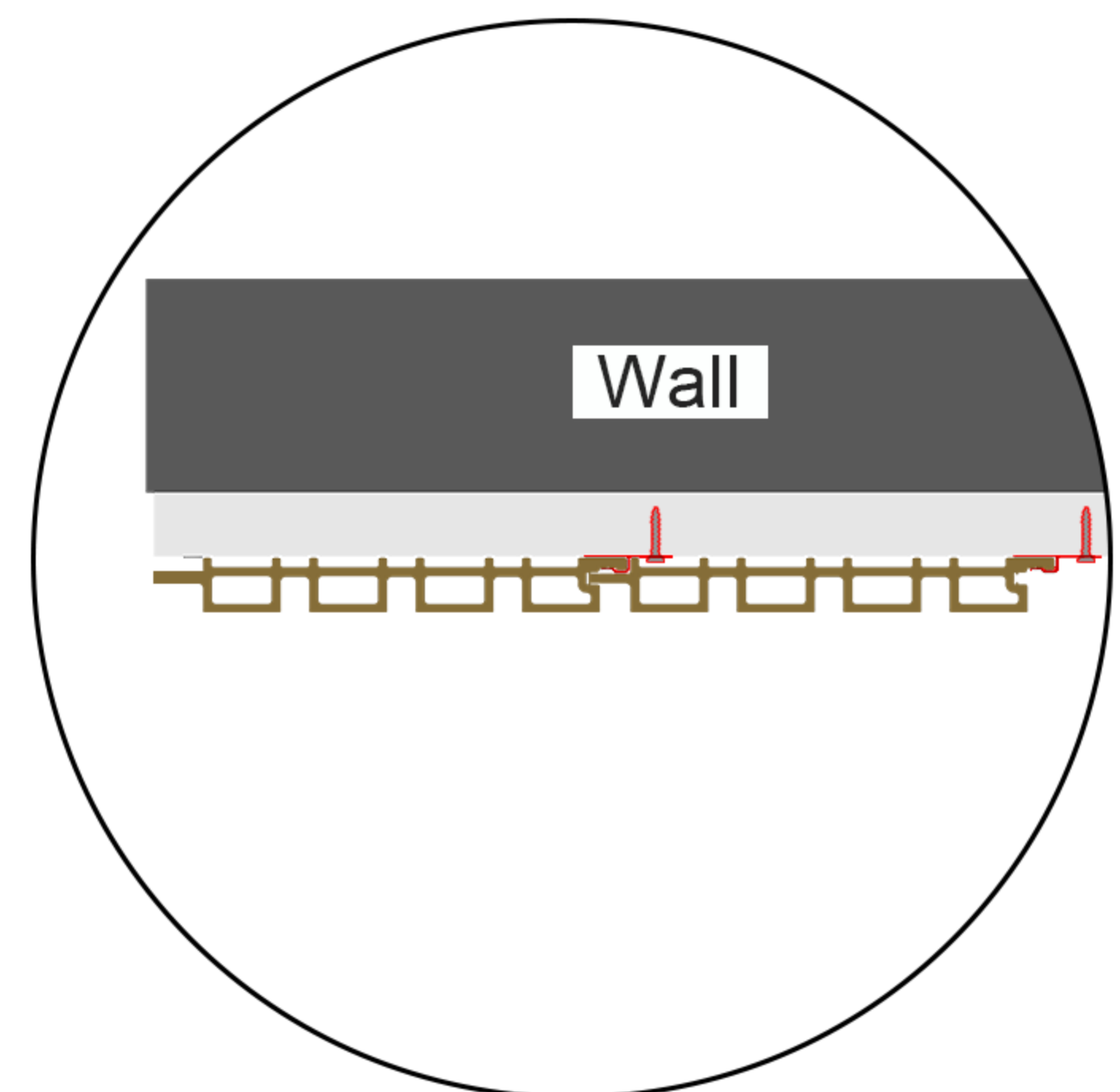

Diagram 4



Detail 4-1

- 4** Repeat step 3 by fixing more wall panels into clips until the remaining wall width is too narrow for a full panel. Measure the distance from the last panel to the corner and designate it as 'a' millimeters (see Detail 5-1). Cut a cladding panel from the insert side to match the measured distance (see Detail 5-2).

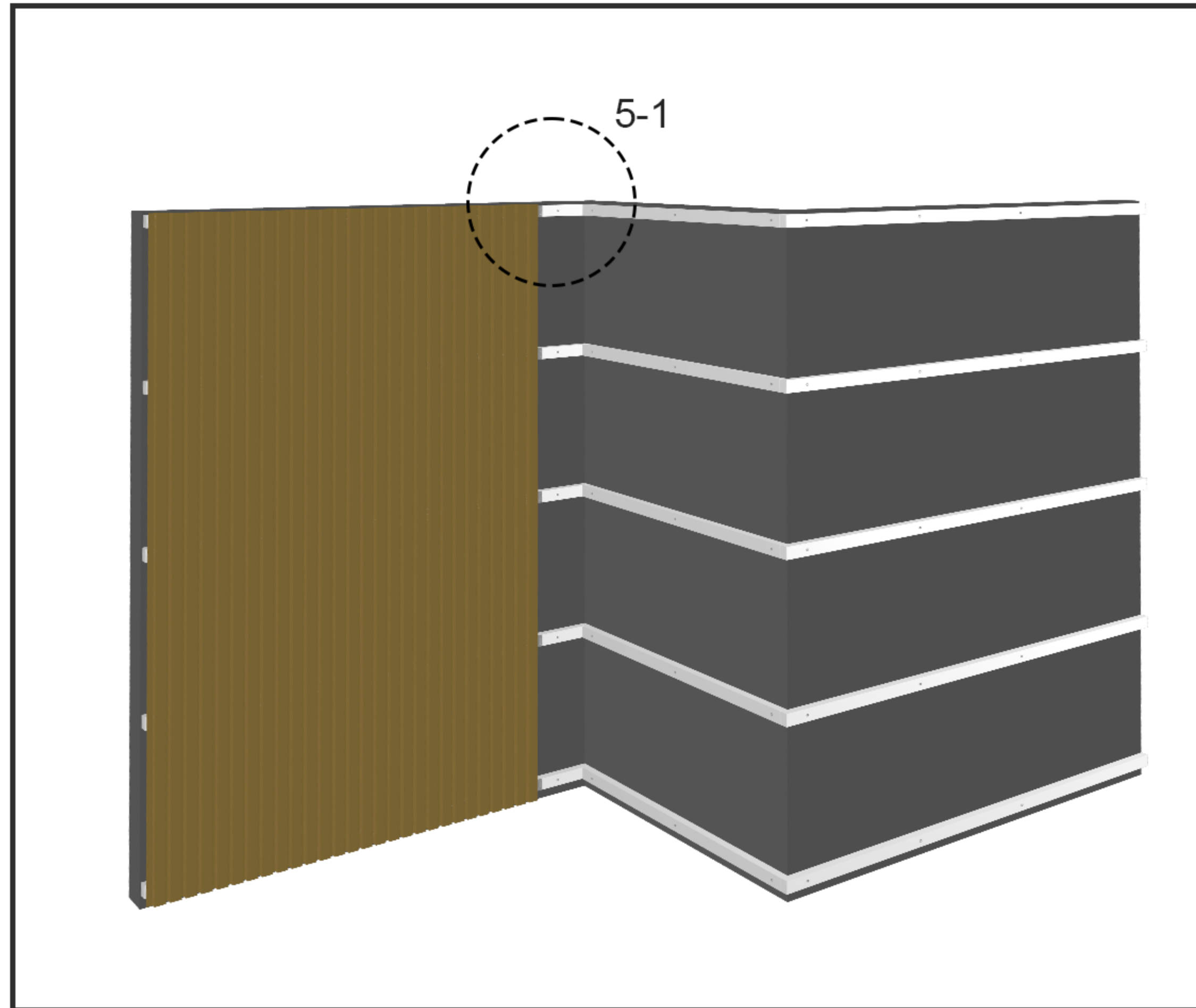
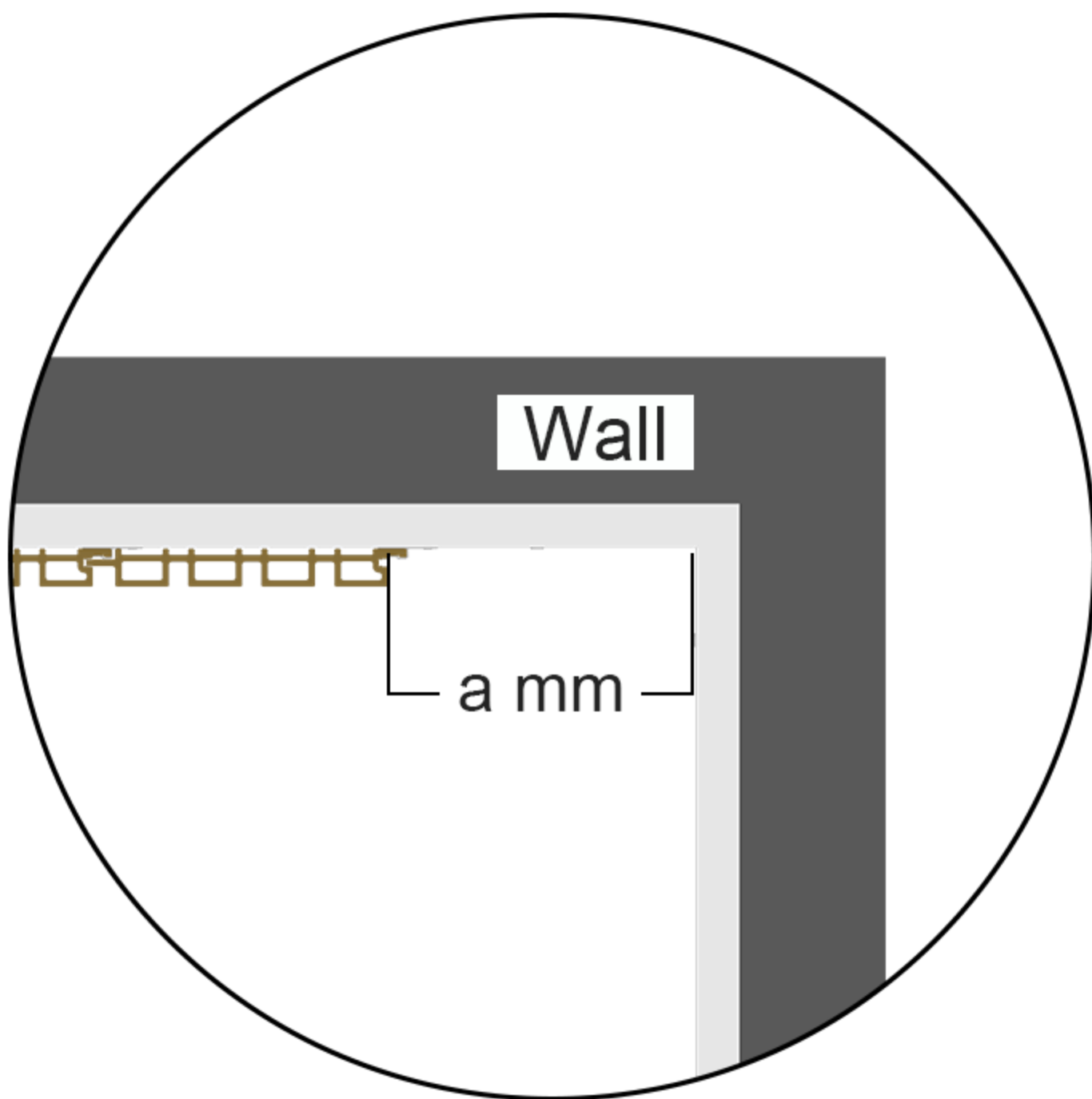
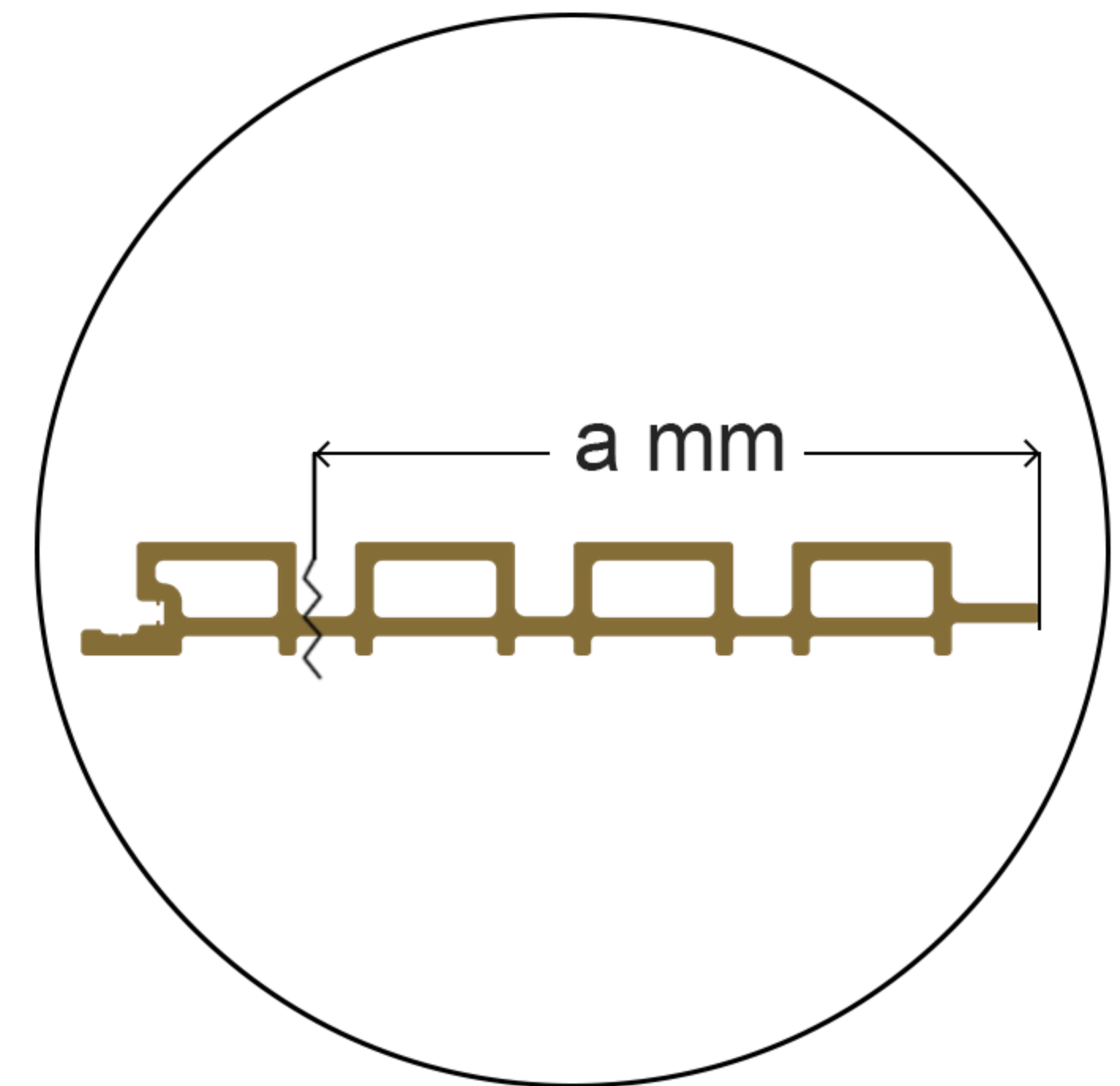

Diagram 5



Detail 5-1



Detail 5-2

- 5** Put the trimmed cladding panel in place and pre-drill holes in suitable positions. Then fix the panel with screws to finish the last board installation on this wall (see Detail 6-1).

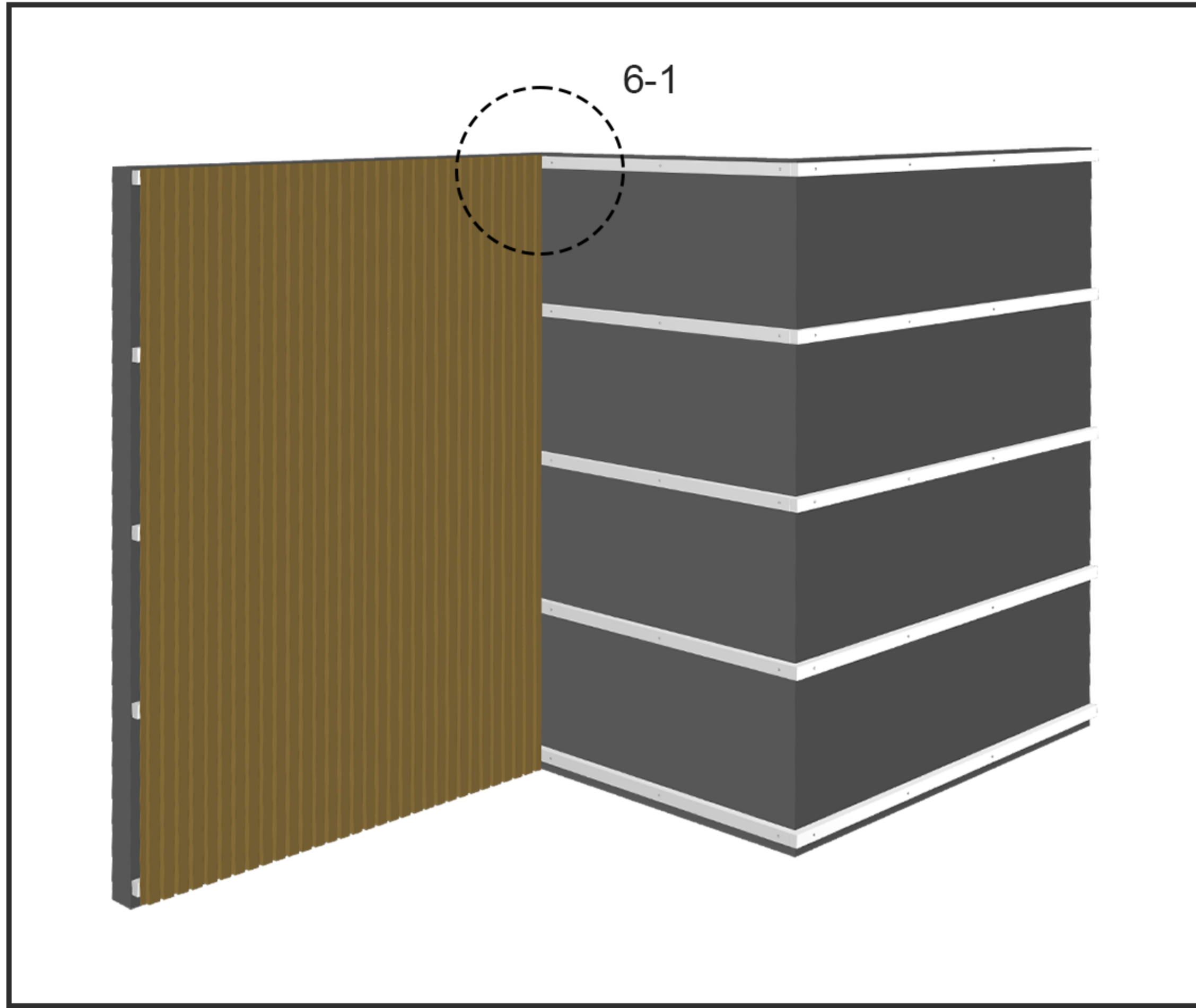
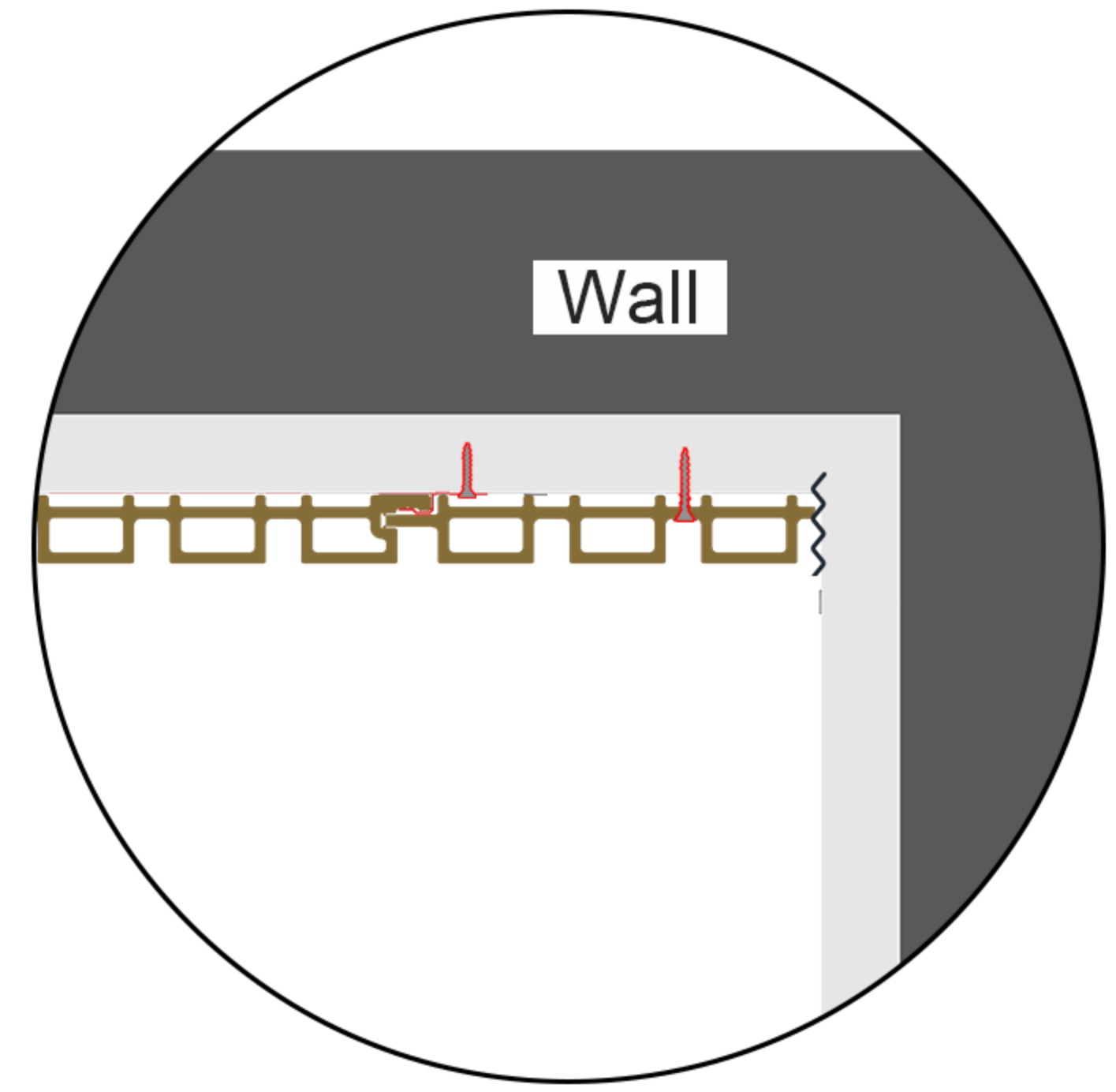

Diagram 6



Detail 6-1

- 6** Install the corner trim onto the outer corner with screws on both sides (see Detail 7-1).

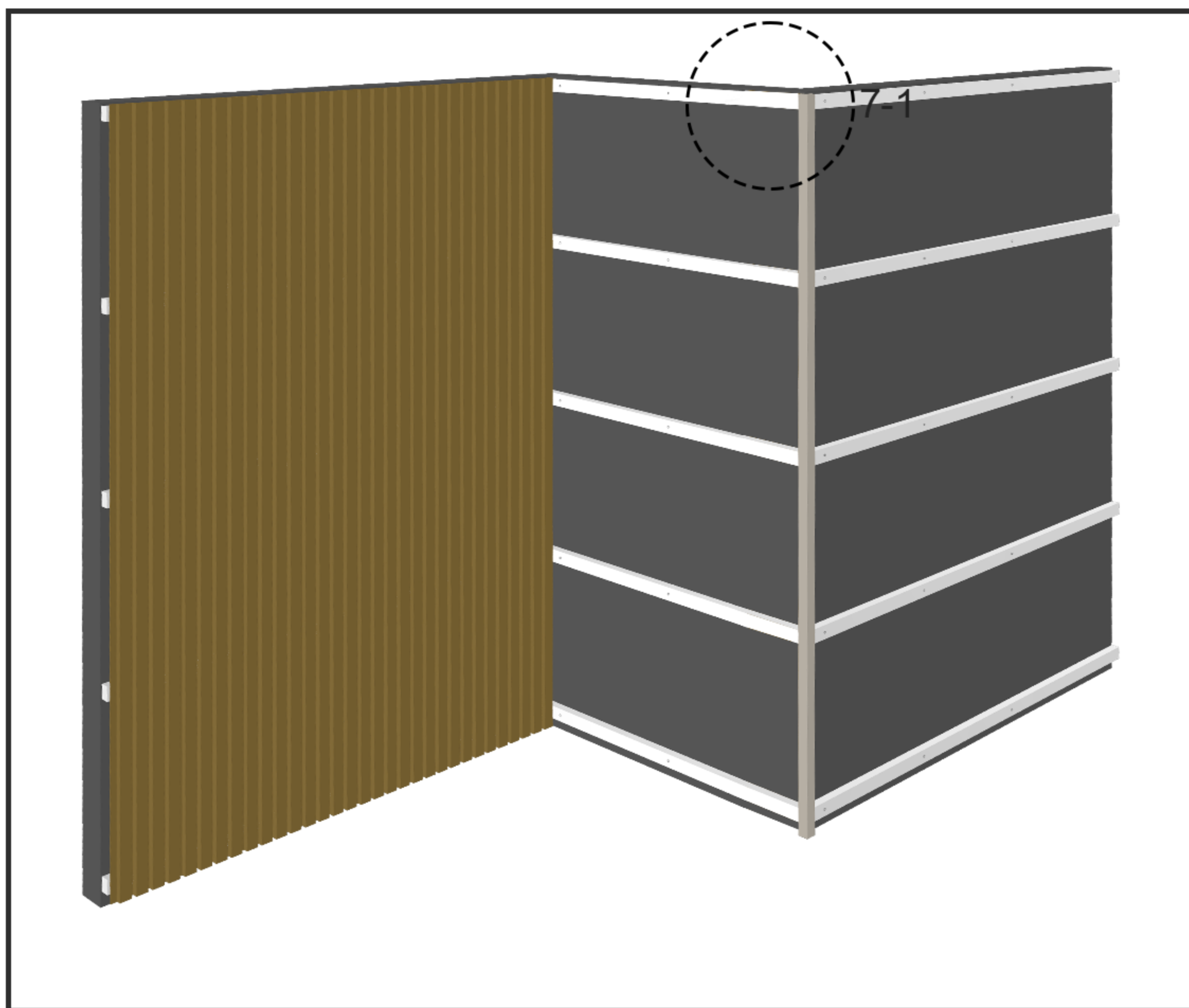
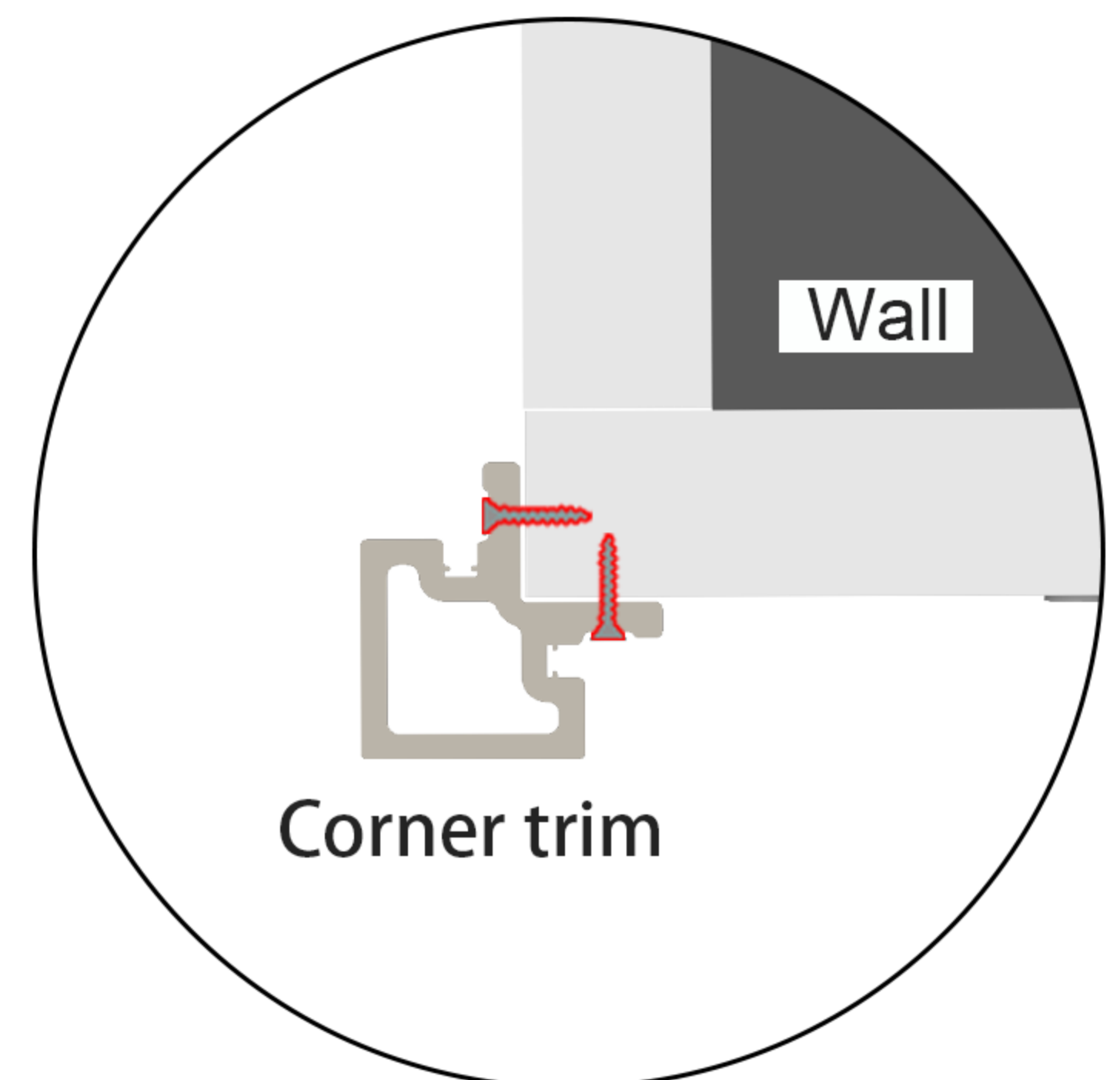

Diagram 7



Detail 7-1

7 Repeat step 3, fixing wall panels into clips (see Diagram 8).

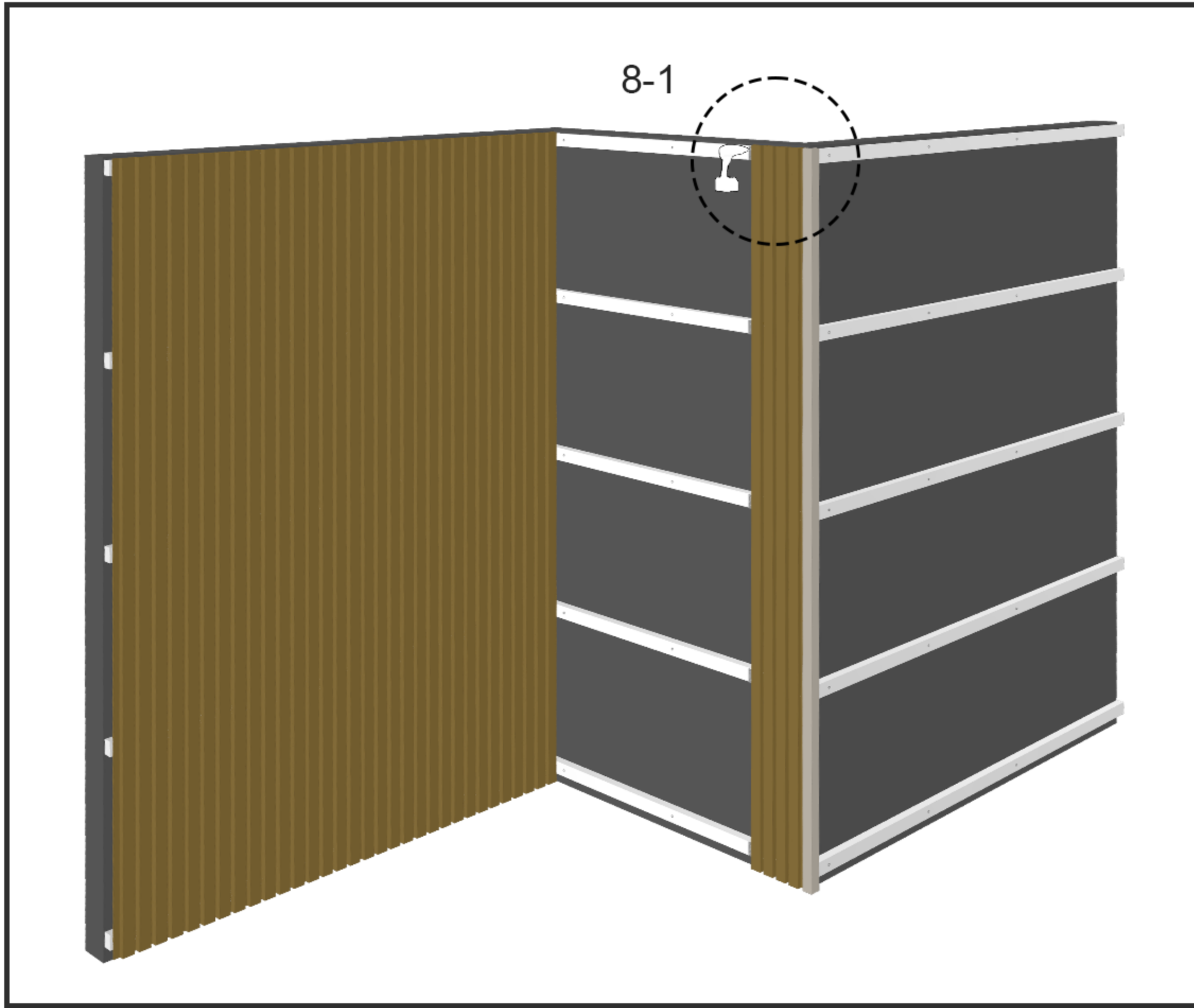
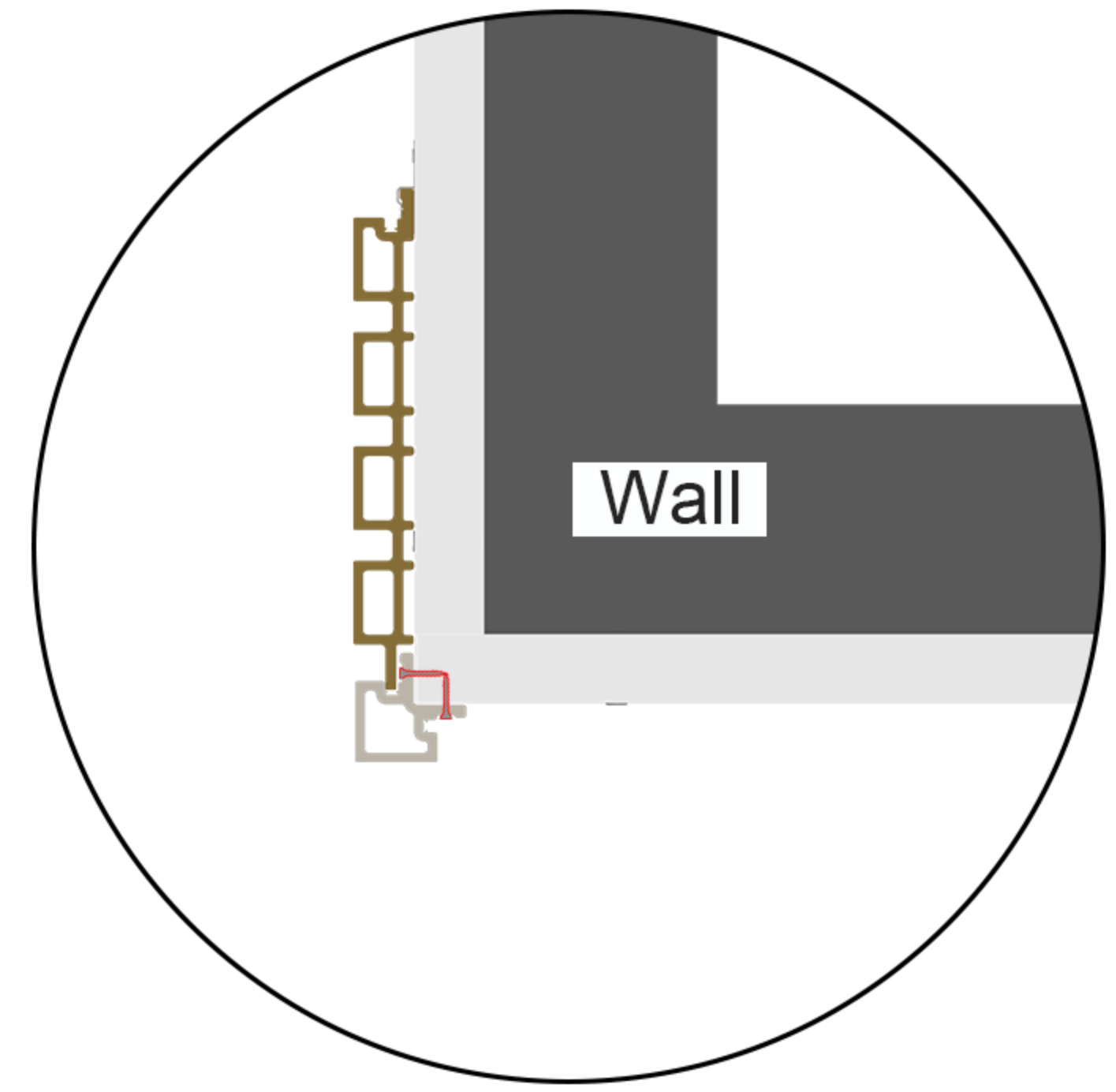

Diagram 8



Detail 8-1

8 Continue installing the clips and cladding in the same fashion as in step 3 until the remaining wall width is too narrow for a full panel (see Detail 9-1). Measure the remaining wall width and cut a panel to fit.

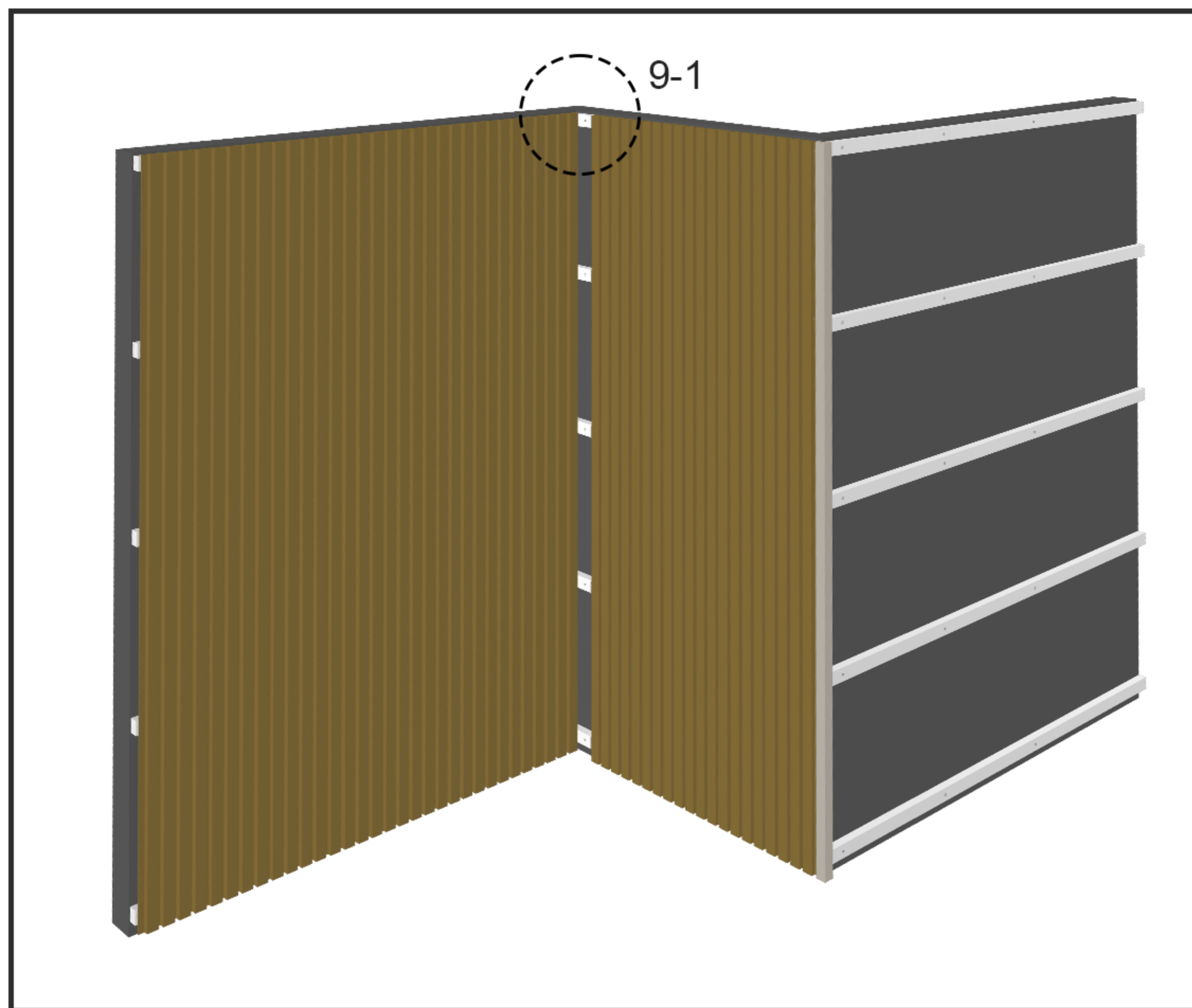
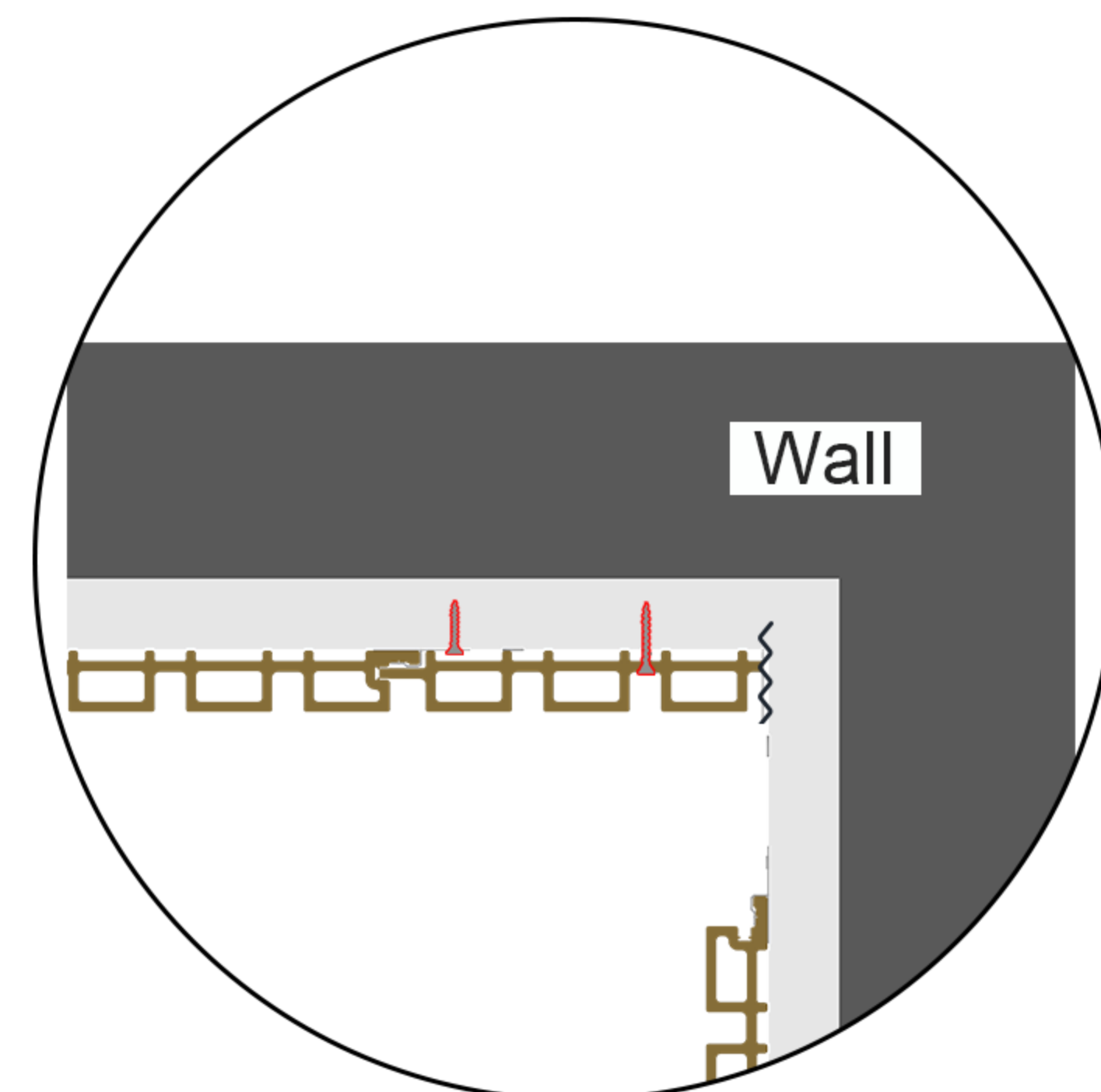

Diagram 9



Detail 9-1

- 9** Fix the trimmed panel with screws (see Detail 10-1). The finished wall should look like Diagram 10.

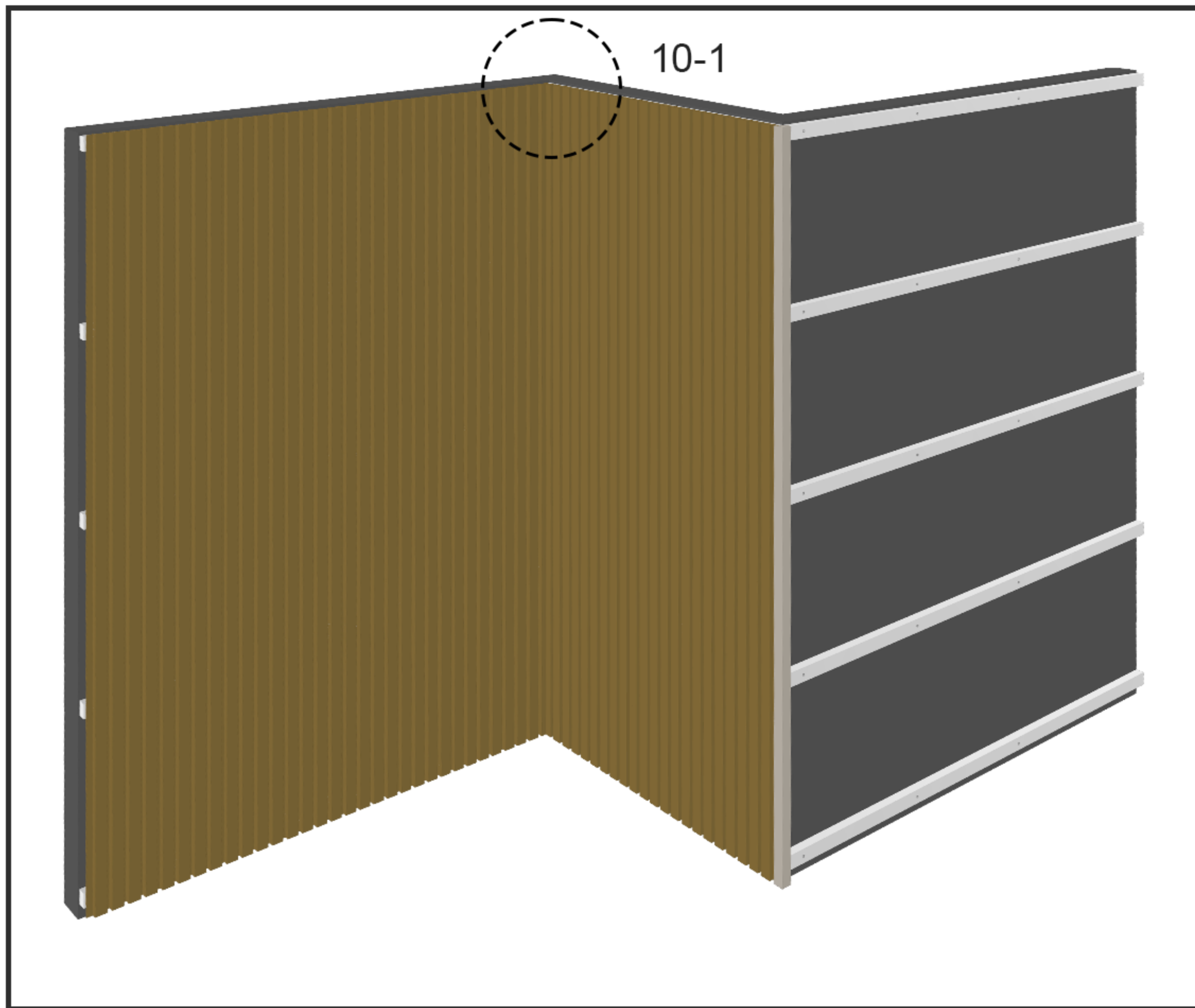
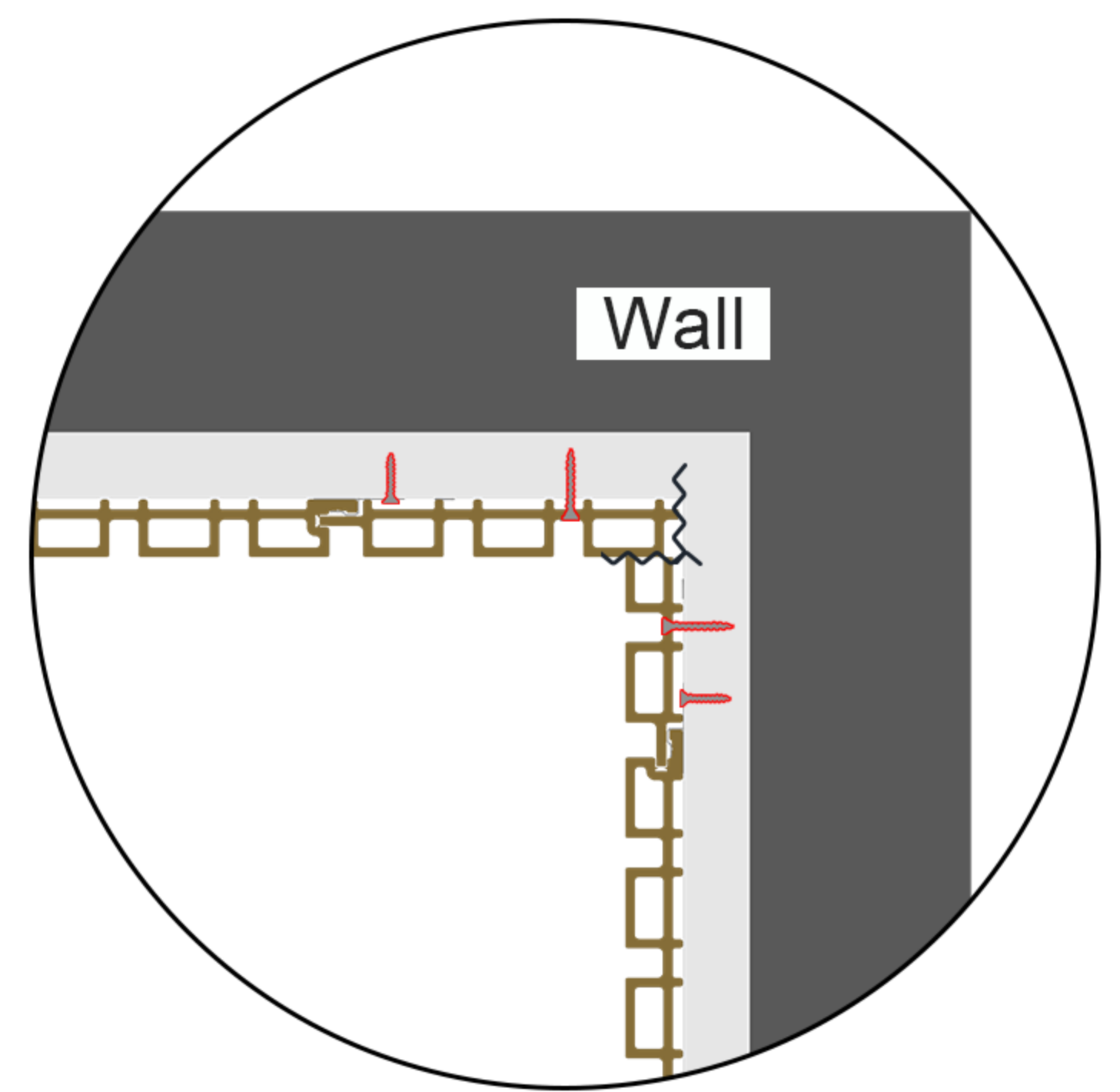

Diagram 10



Detail 10-1

- 10** Insert the cladding panel into the corner trim on the other side of the corner (see Detail 11-1). Continue installing cladding panels with connector clips until the remaining wall width is too narrow for a full panel. Measure the remaining wall width and cut a cladding panel to fit. Then use screws to install the cladding panel onto the joists (see Detail 12-1).

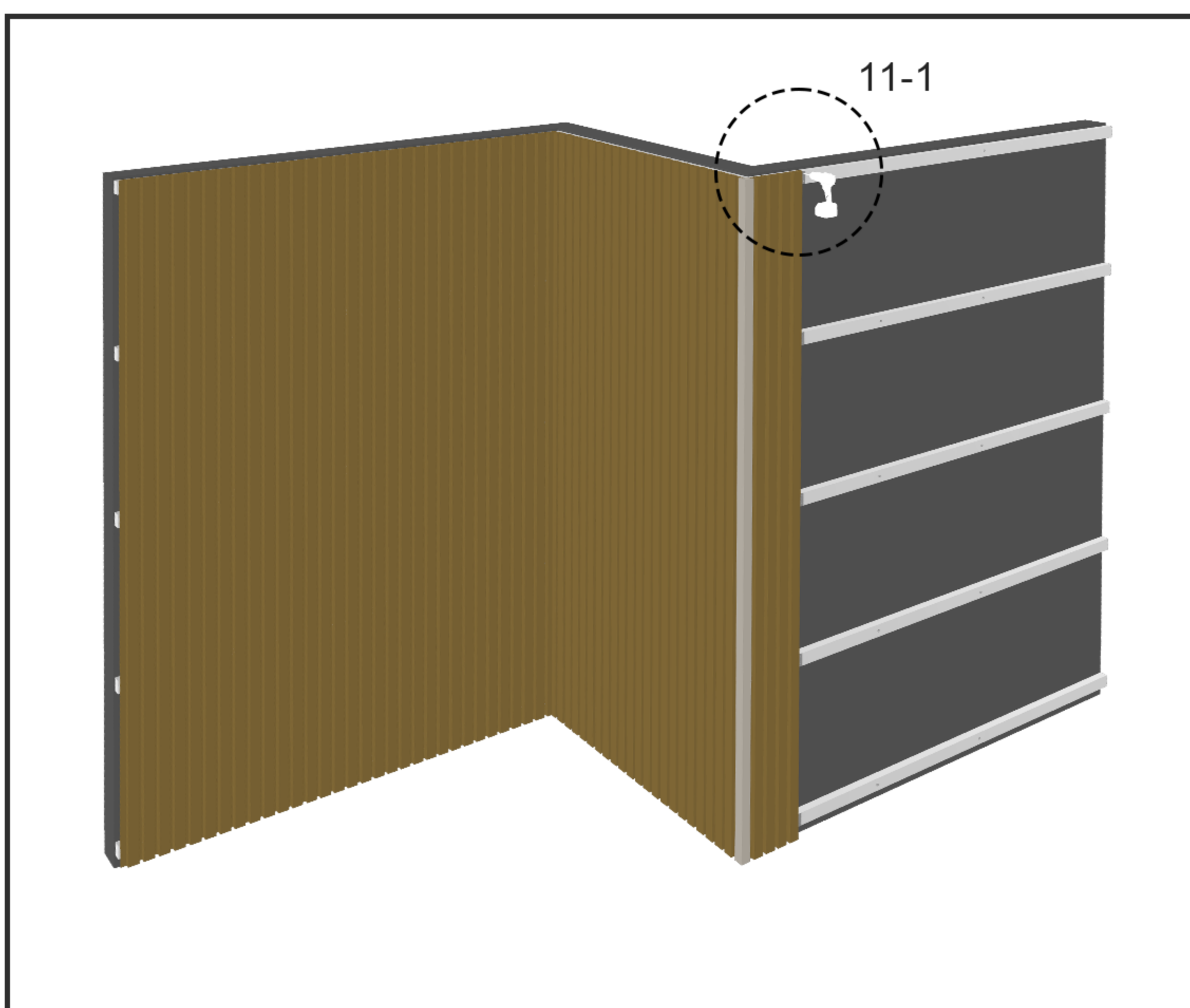

Diagram 11

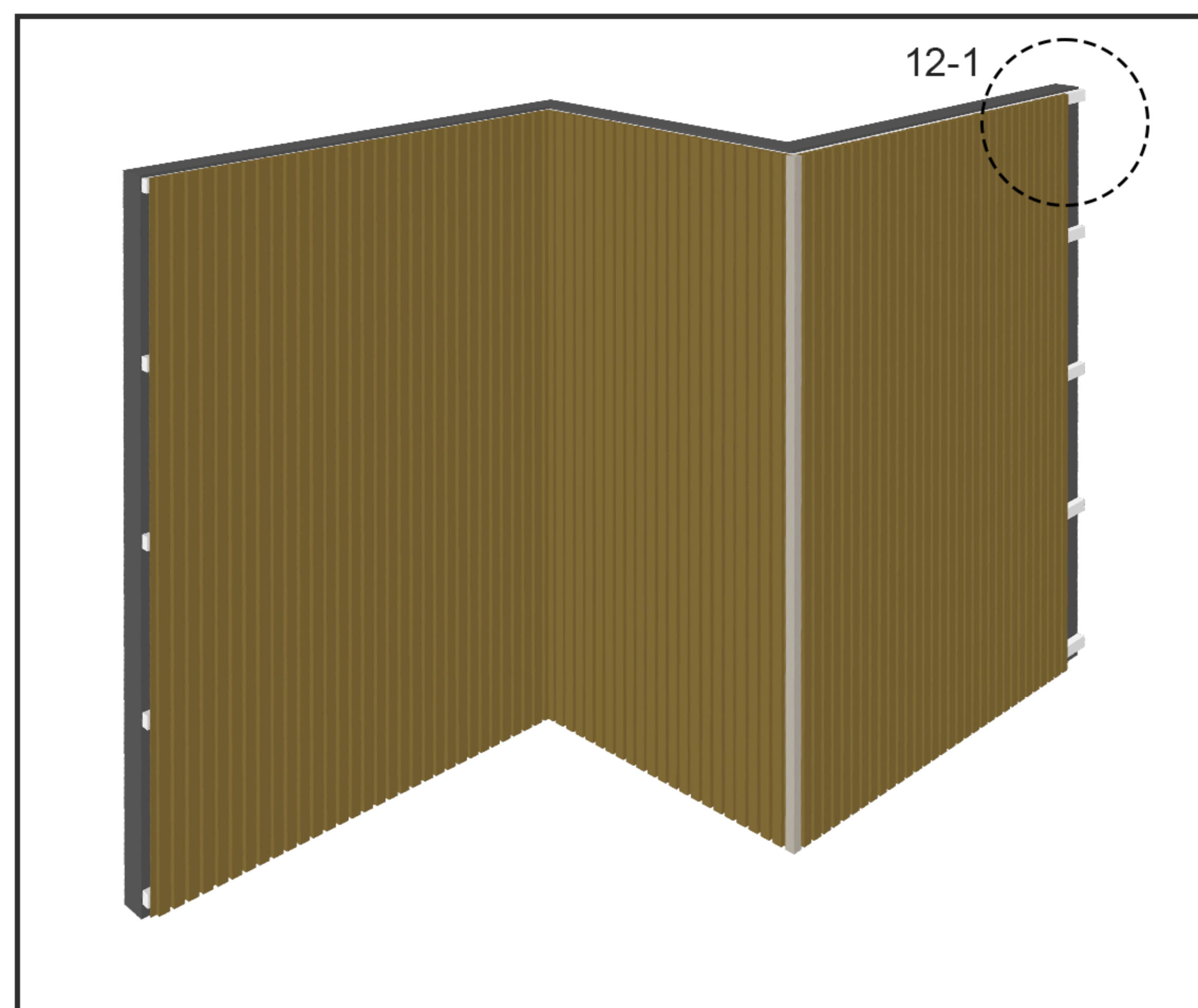
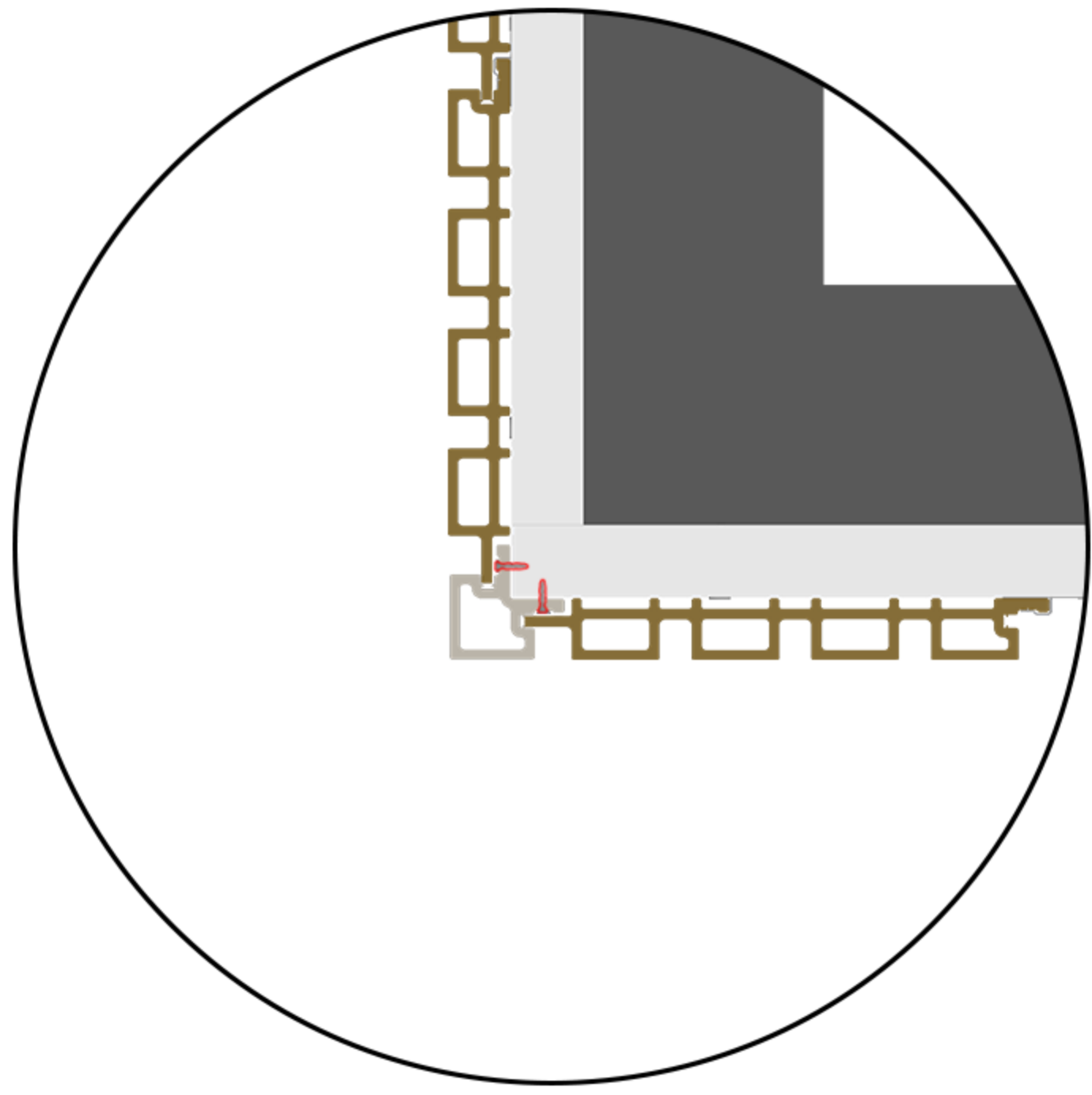
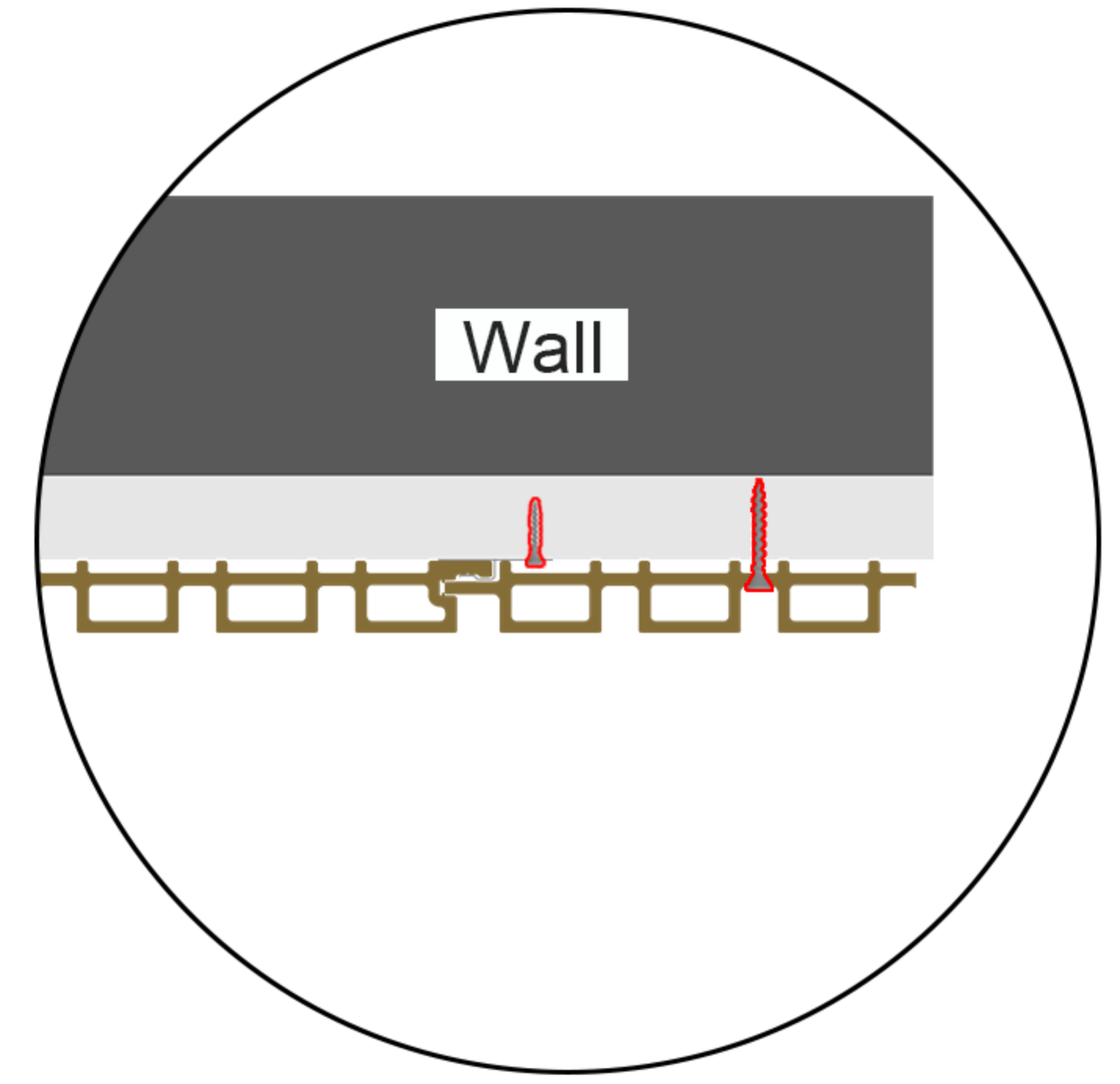

Diagram 12



Detail 11-1



Detail 12-1

11 Take L trims and cover both sides at the beginning and the very end. Pre-drill holes in suitable positions, then fix the L trims with screws (as Detail 13-1).

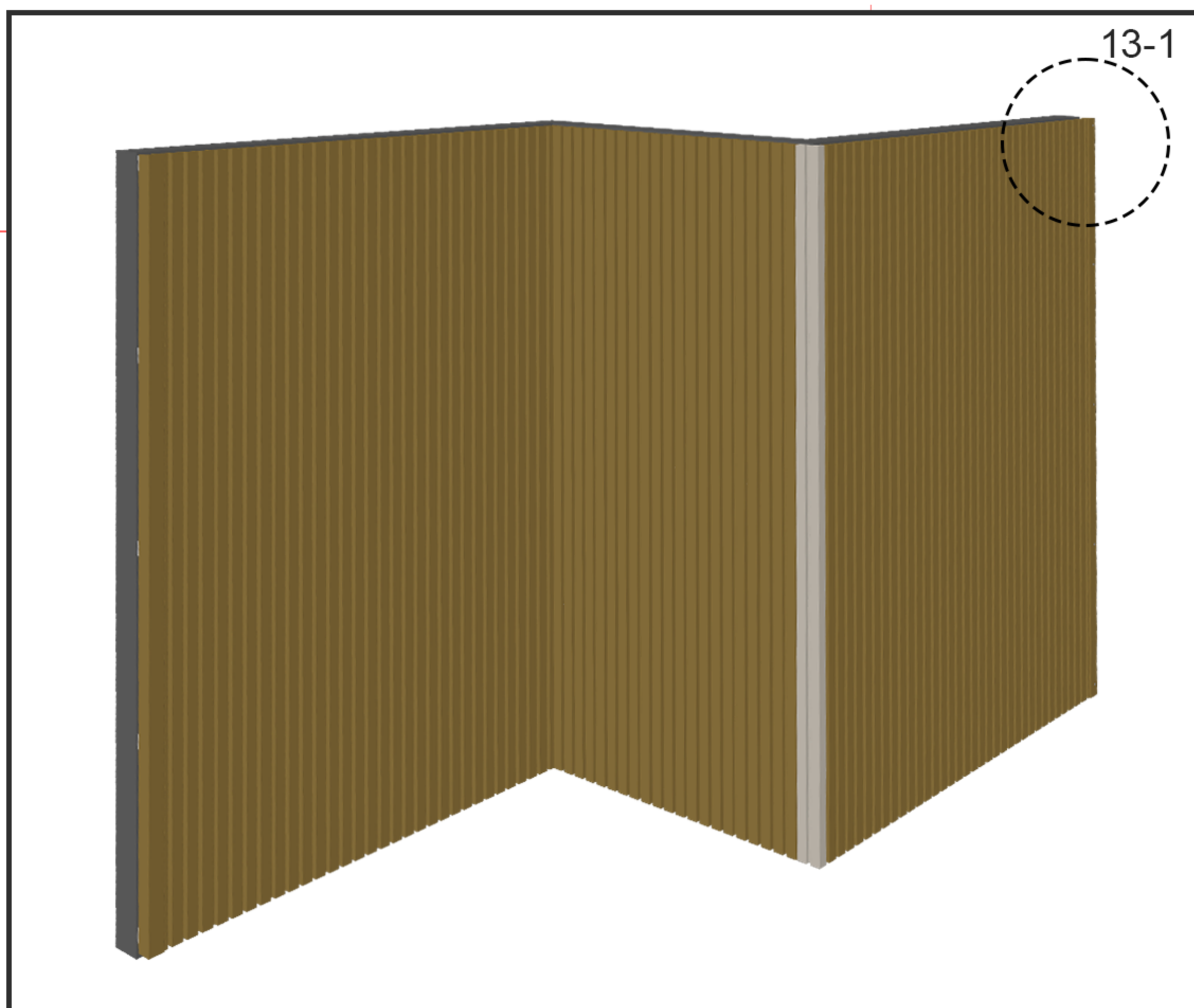
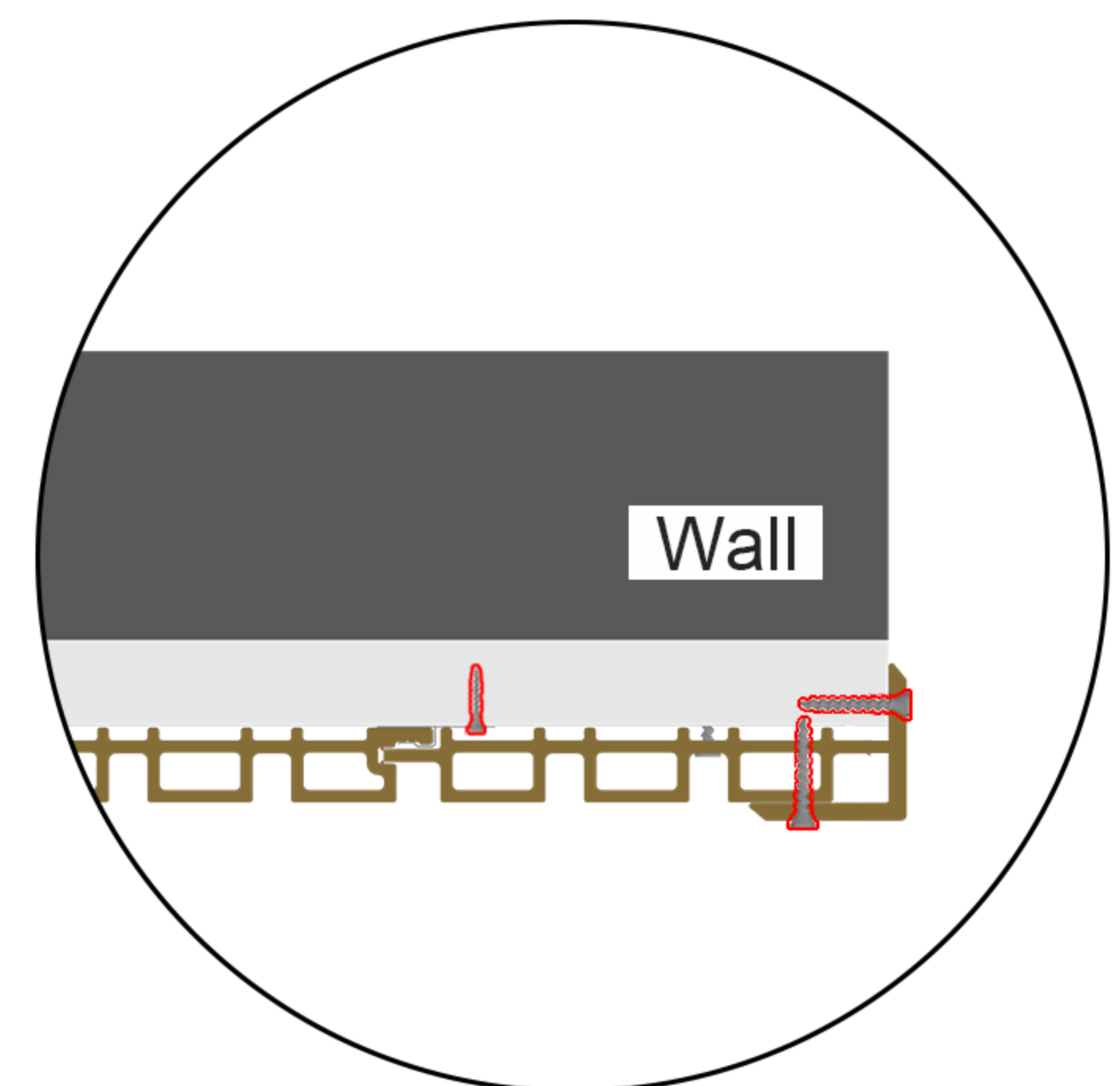

Diagram 13



Detail 13-1

Horizontal Installation

- 1** Install joists onto the wall with a 500mm span between adjacent joists. The lower end of the joists should be positioned 5mm above the ground. Then install the starter clips into the joists at a position that is 5mm higher than the lower end of the joists (see Detail 1-1).

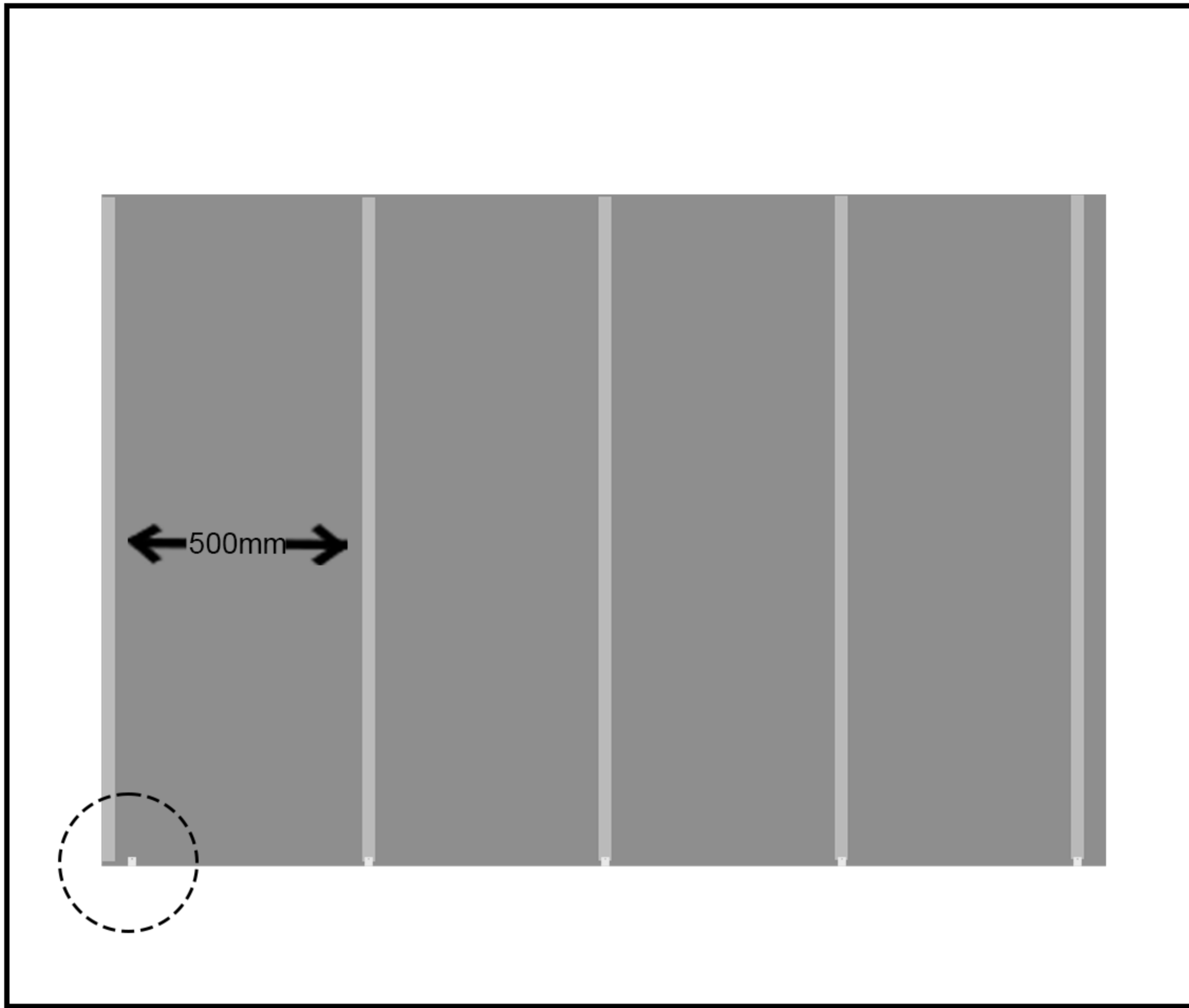
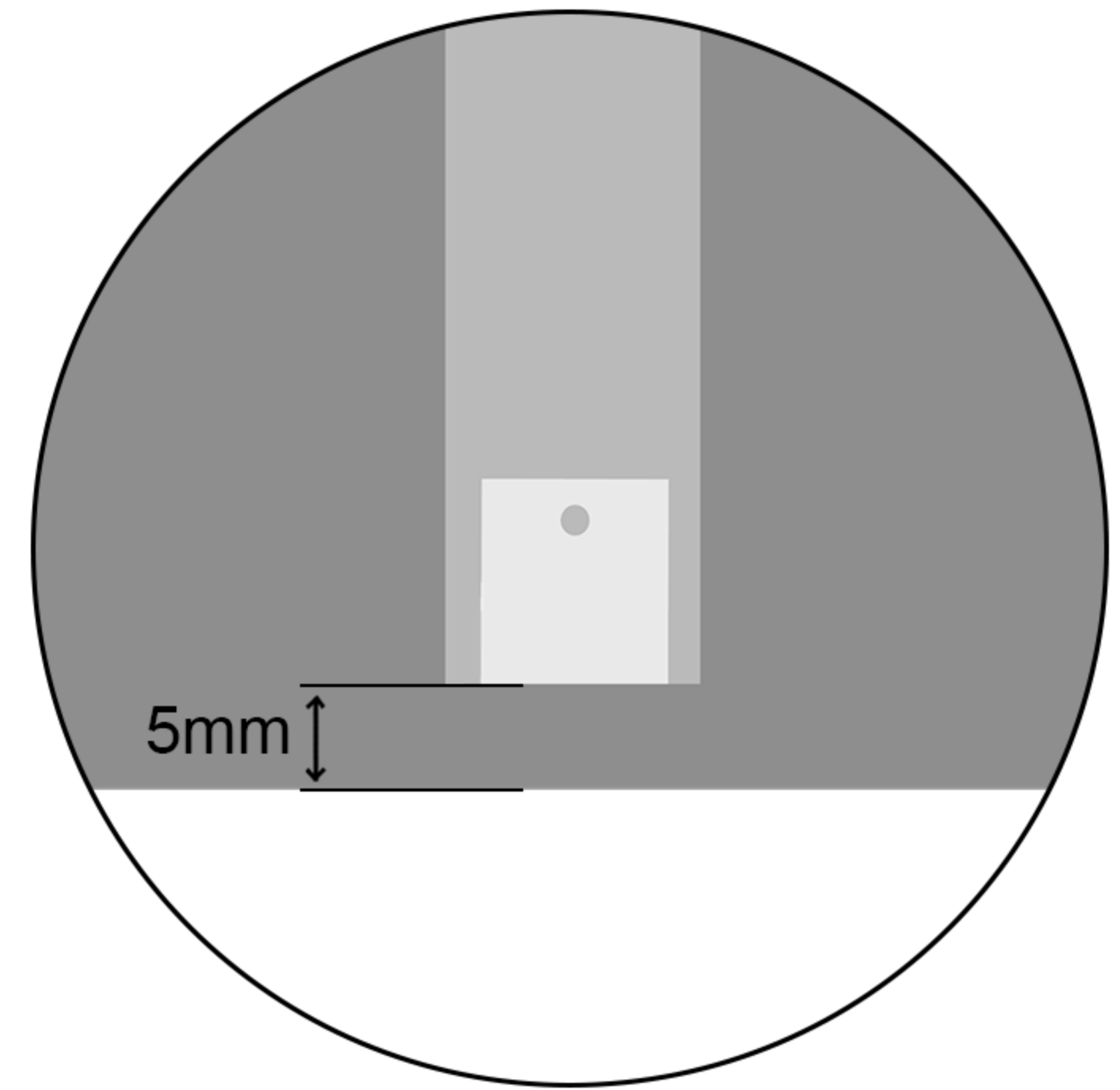

Diagram 1



Detail 1-1

- 2** Insert the first cladding panel into the starter clips as shown in Detail 2-1.

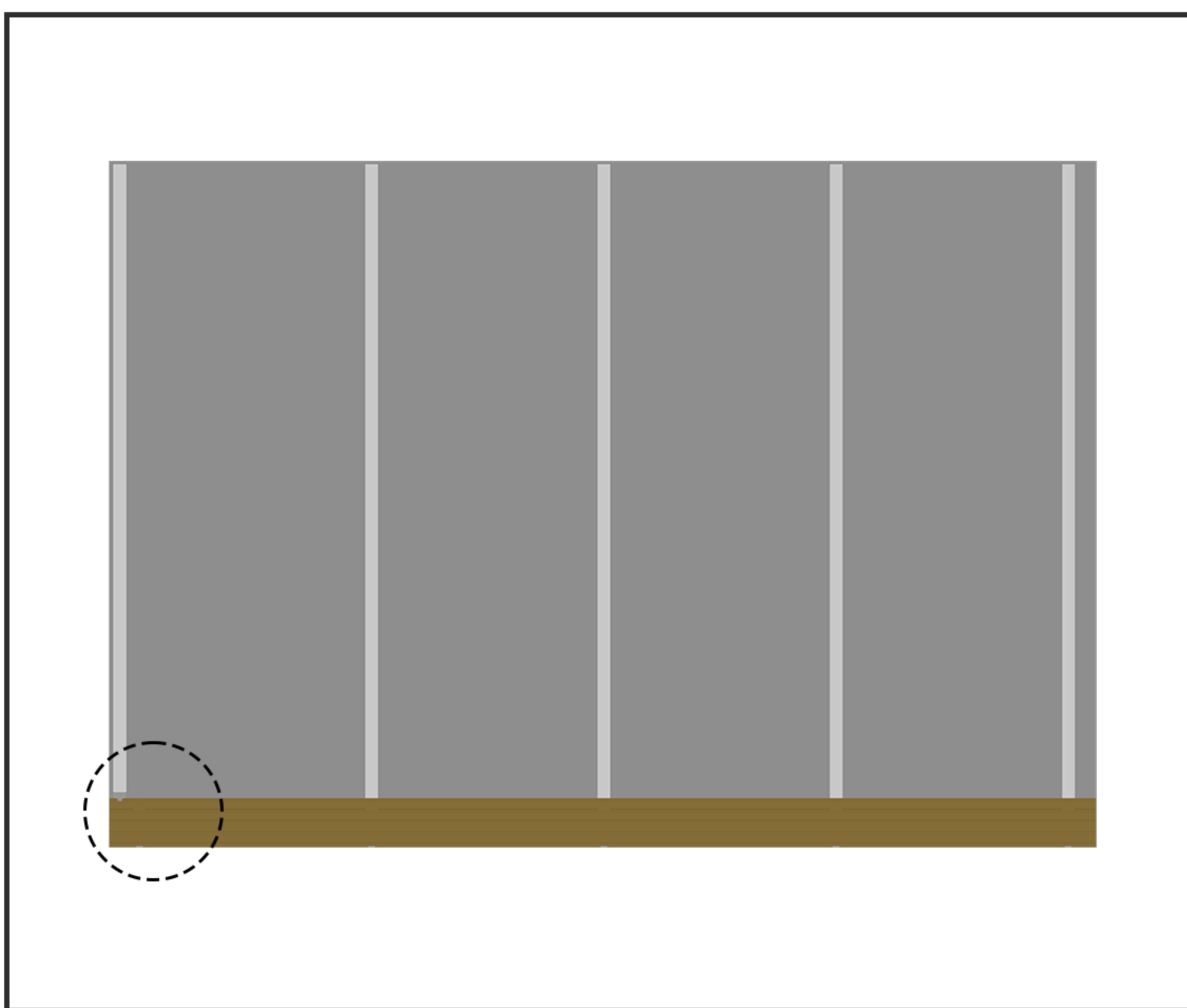
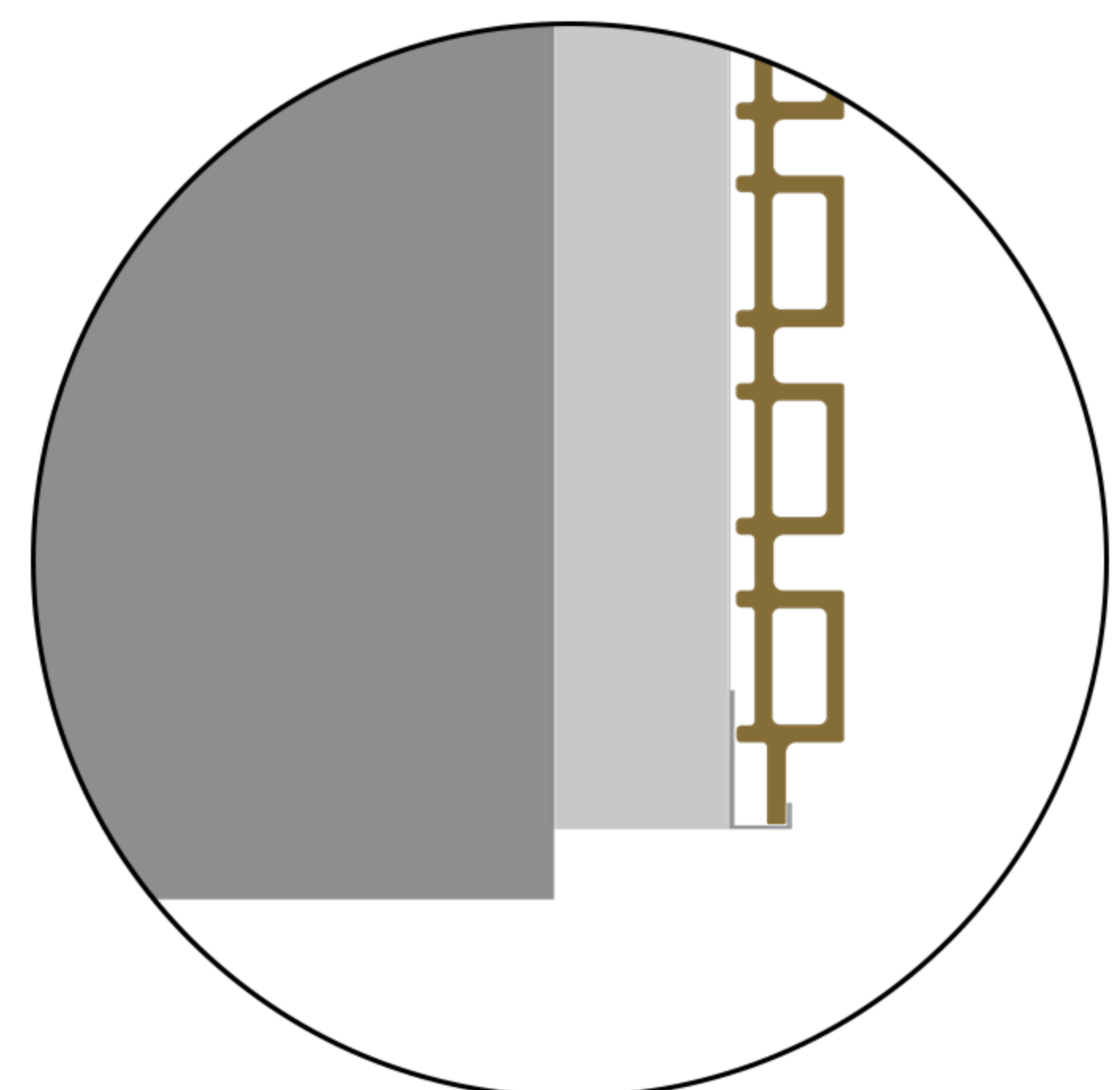

Diagram 2



Detail 2-1

- 3** Insert connector clips in line with the upper side of the wall panel, and screw them onto the joists (see 3-1).

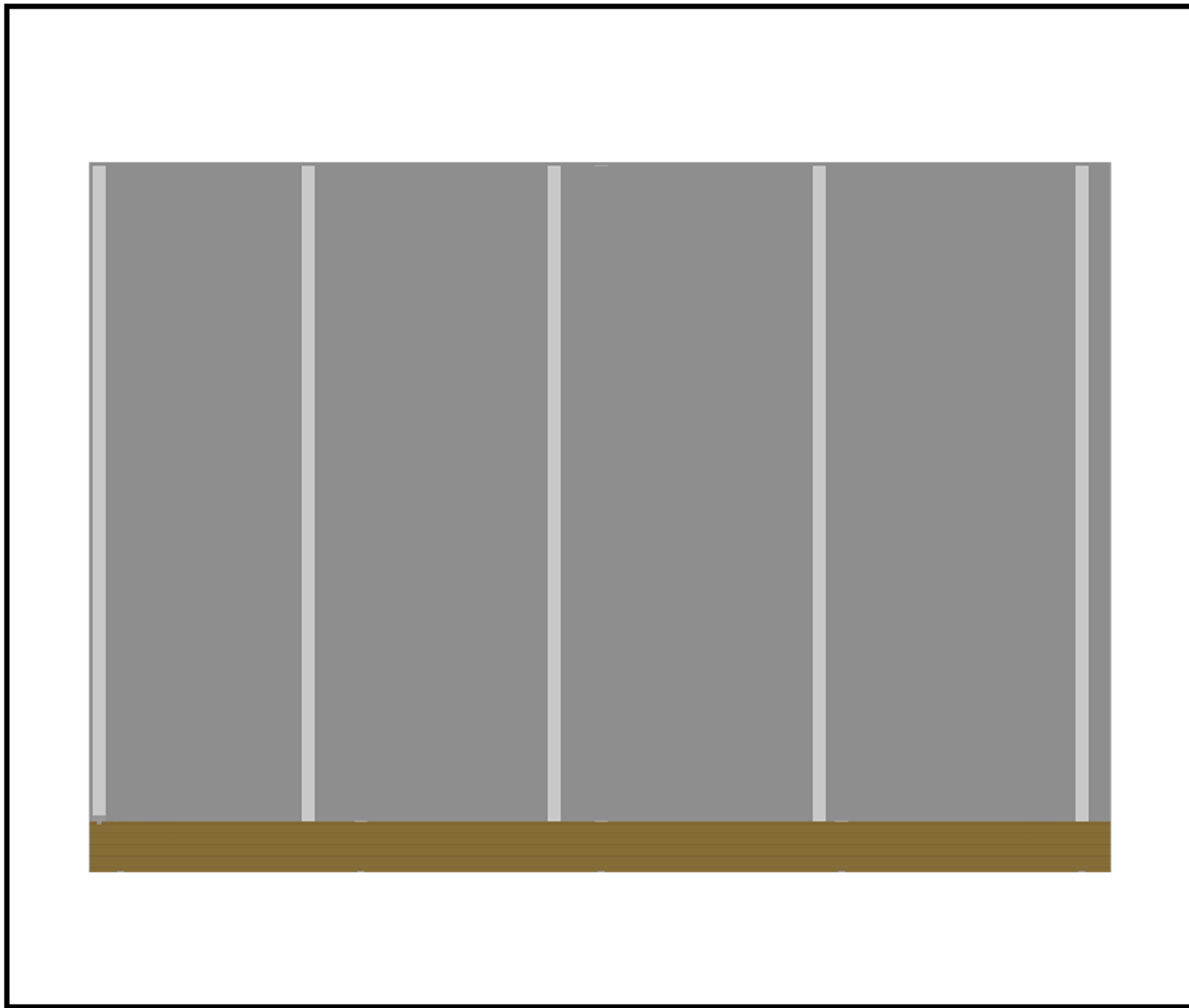
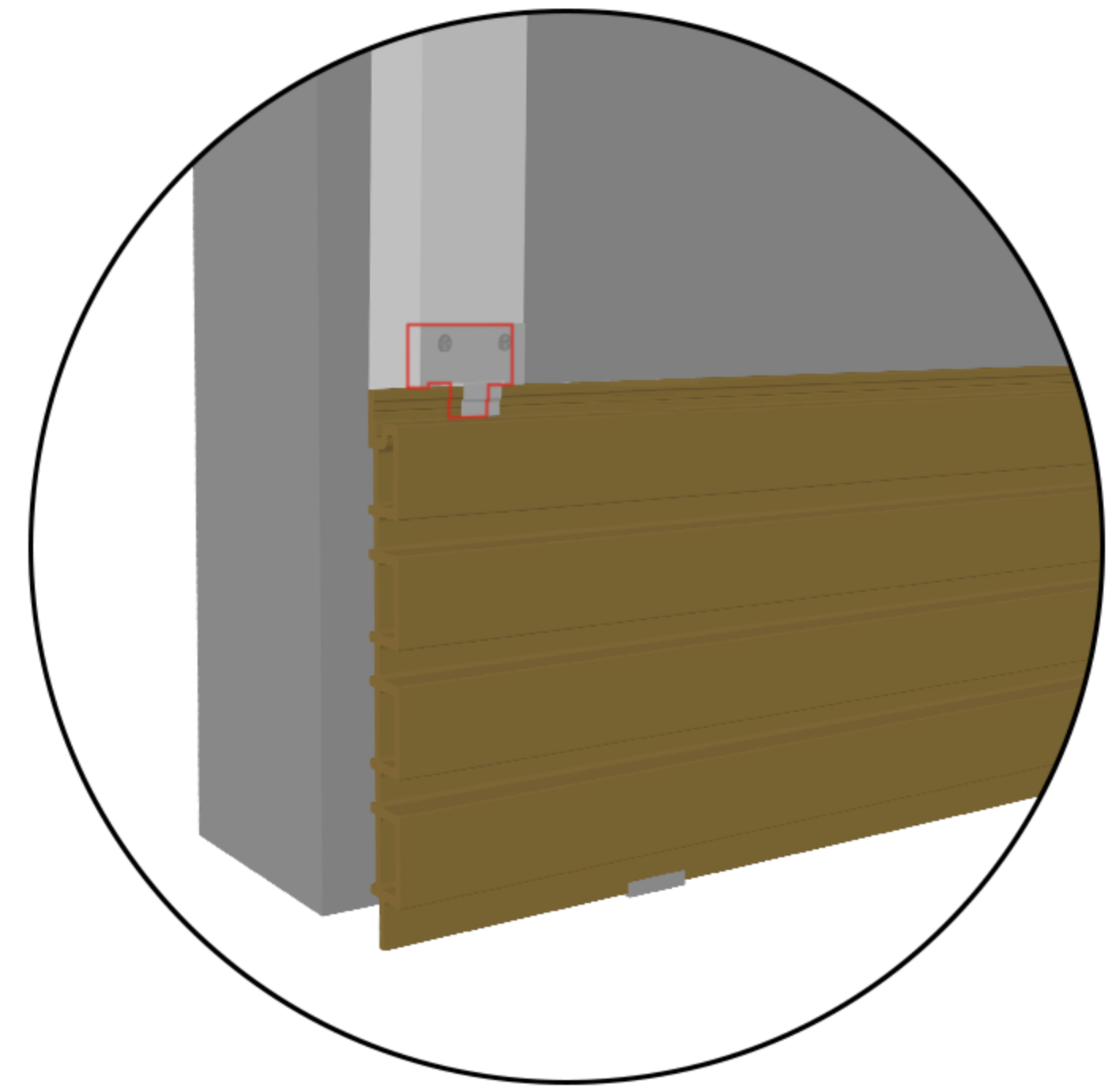

Diagram 3



Detail 3-1

- 4** After the last cladding panel is installed, put L trims on both sides of the cladding project and fix them to the cladding panels with screws. The installation is finished.

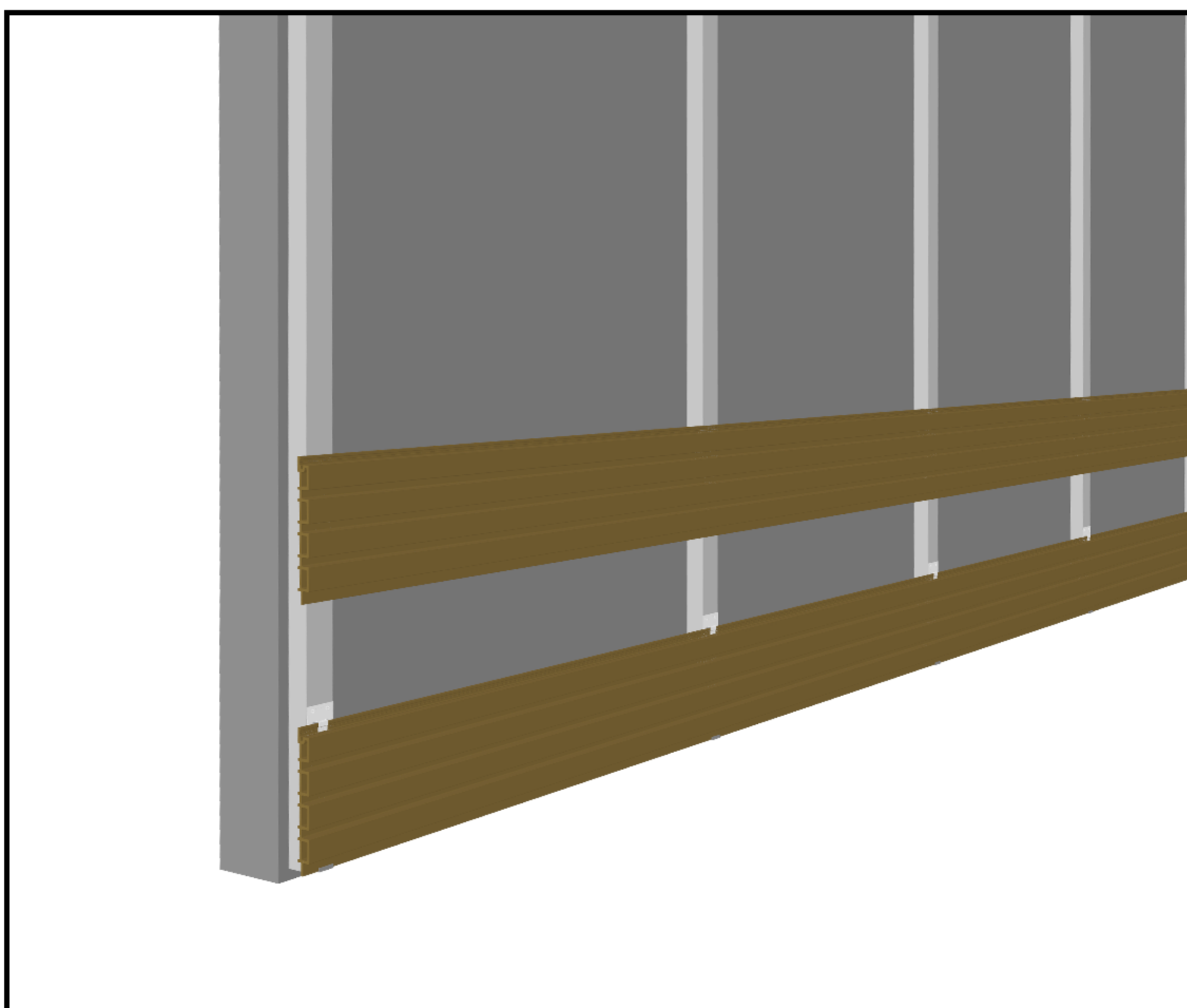

Diagram 4

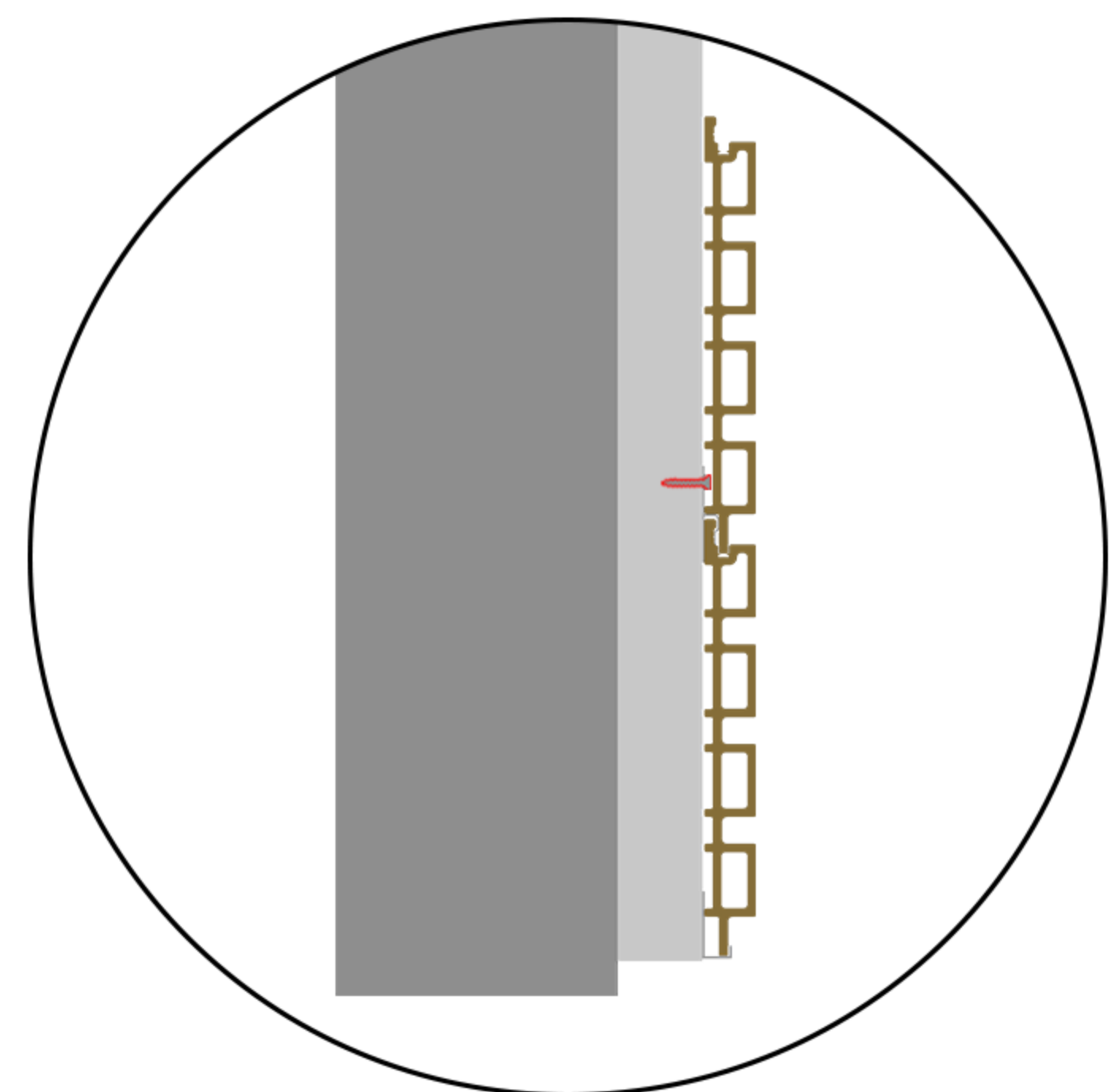

Diagram 5

- 5** After the last cladding panel is installed, put L trims on both sides of the cladding project and fix them to the cladding panels with screws. The installation is finished.

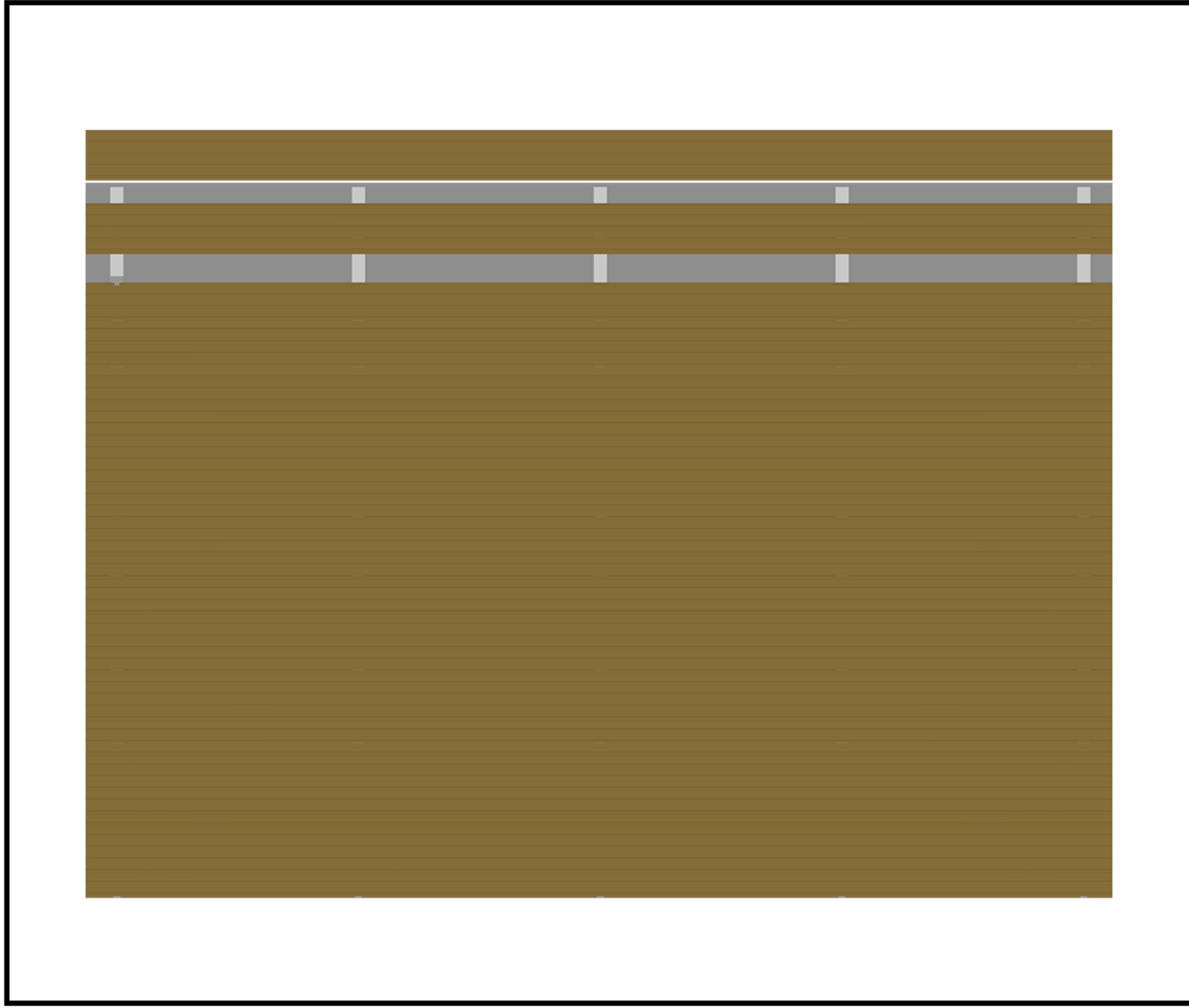

Diagram 4

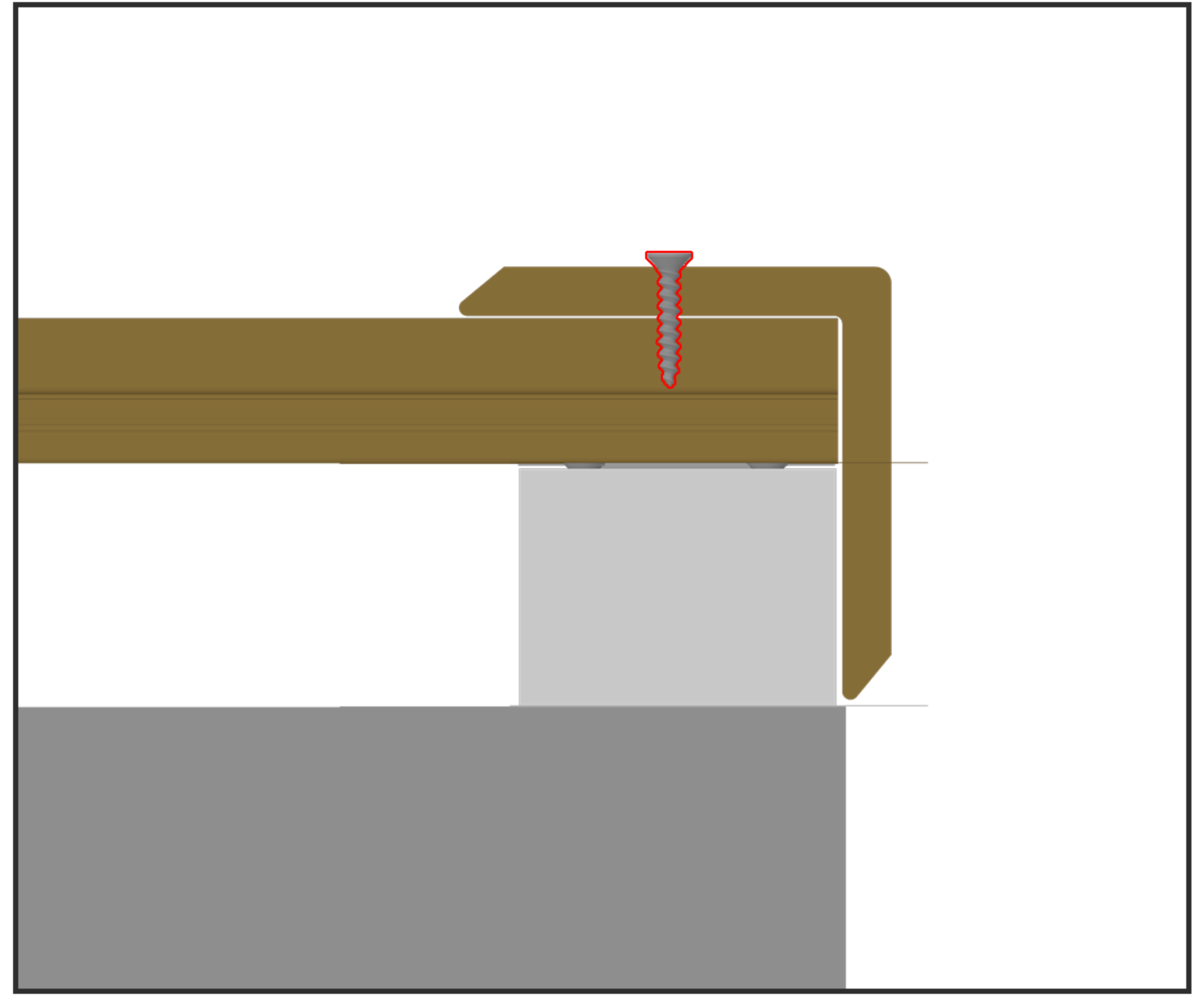

Diagram 5



FEELINGWOOD CO., LTD.

Add: 10611 Harwin Dr Suite 406 Houston TX, USA 77036

Tel: +1(832) 605-5896

Email: lucio@feelingwoodwpc.com

www.feelingwoodwpc.com



Feelingwood